

DO NOT SCALE FROM THIS PRINT

SMPM-PS-P-XX-ST-SM-1

GENDER
-PS: PLUG SMOOTH BORE

TYPE
-P: PCB

FINISH
-EG: 50μ" HEAVY GOLD CENTER CONTACT,
10μ" GOLD OUTER BODY

OPTION
-1

TERMINATION
-SM: SURFACE MOUNT

ORIENTATION
-ST: STRAIGHT

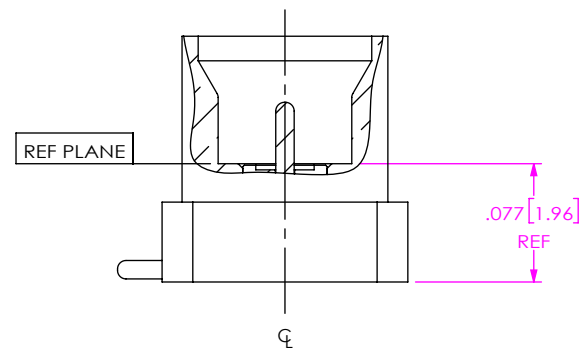
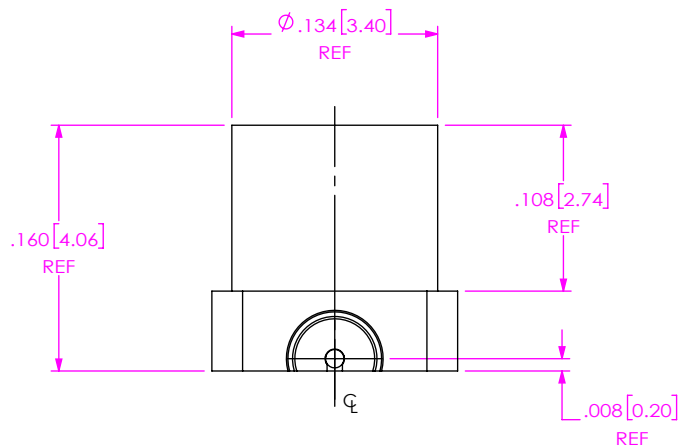
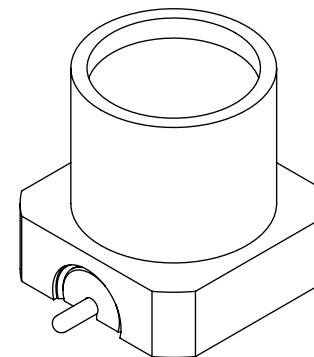
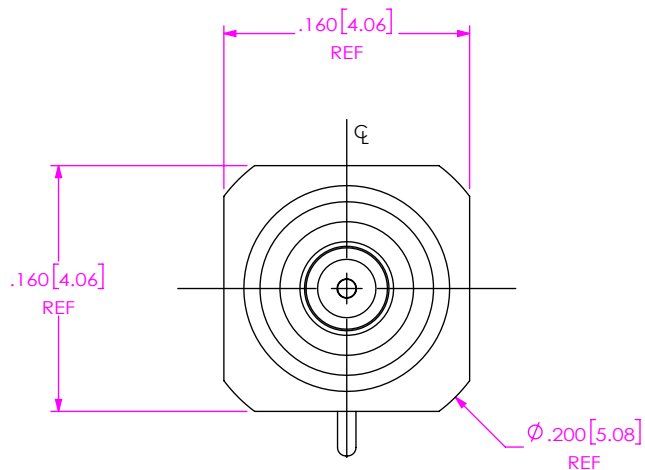

NOTES:

- MATERIAL:
BEADS: VICTREX POLYMER.
CONTACT: BERYLLIUM COPPER.
BODY: BRASS ALLOY.
- FINISH:
CONTACT, FERRULE, OUTER CONTACT:
-E: GOLD OVER NICKEL PLATE, 50-100 μIN MIN GOLD OVER 50-100 μIN MIN NICKEL.
-G: GOLD OVER NICKEL PLATE, 10-30 μIN MIN GOLD OVER 50-100 μIN MIN NICKEL.

UNLESS OTHERWISE SPECIFIED, DIMENSIONS ARE IN INCHES. TOLERANCES ARE: DECIMALS ANGLES .XX: ±.01 1° .XXX: ±.002 .XXXX: ±.0005	* PROPRIETARY NOTE * THIS DOCUMENT CONTAINS CONFIDENTIAL AND PROPRIETARY INFORMATION AND ALL DESIGN, MANUFACTURING, REPRODUCTION, USE, PATENT RIGHTS AND SALES RIGHTS ARE EXPRESSLY RESERVED BY SAMTEC, INC. THIS DOCUMENT SHALL NOT BE DISCLOSED, IN WHOLE OR PART, TO ANY UNAUTHORIZED PERSON OR ENTITY NOR REPRODUCED, TRANSFERRED OR INCORPORATED IN ANY OTHER PROJECT IN ANY MANNER WITHOUT THE EXPRESS WRITTEN CONSENT OF SAMTEC, INC.		
		520 PARK EAST BLVD, NEW ALBANY, IN 47150 PHONE: 812-944-6733 FAX: 812-948-5047 e-Mail: info@SAMTEC.com code 55322	
DO NOT SCALE DRAWING SHEET SCALE: 8:1		DESCRIPTION: PLUG, SURFACE MOUNT, SMPM(F)	
		DWG. NO. SMPM-PS-P-XX-ST-SM-1	
		BY: ADAM H. 2/3/2020	SHEET 1 OF 3

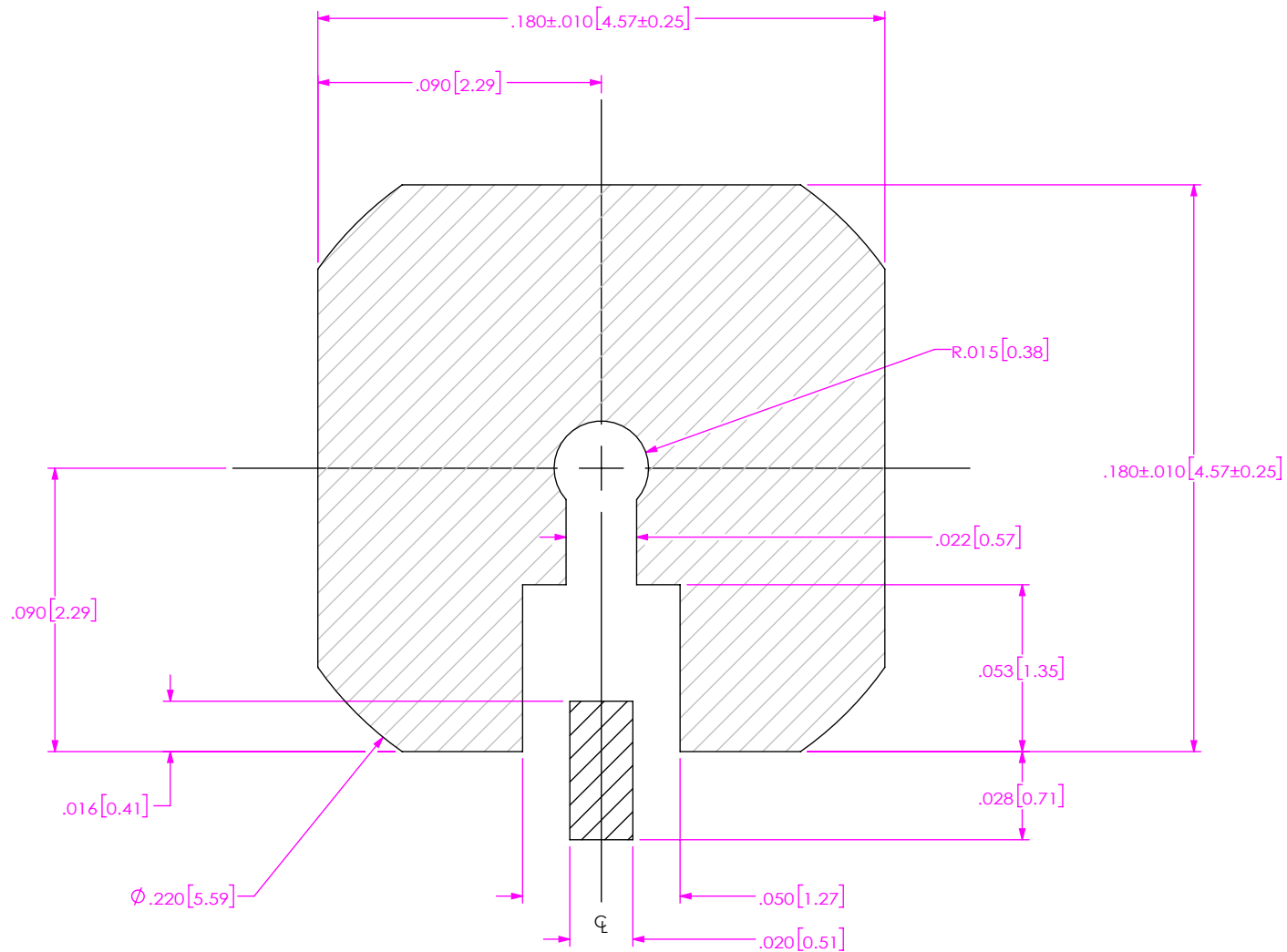

RECOMMENDED FOOTPRINT

<p>PROPRIETARY NOTE</p> <p>THIS DOCUMENT CONTAINS CONFIDENTIAL AND PROPRIETARY INFORMATION AND ALL DESIGN, MANUFACTURING, REPRODUCTION, USE, PATENT RIGHTS AND SALES RIGHTS ARE EXPRESSLY RESERVED BY SAMTEC, INC. THIS DOCUMENT SHALL NOT BE DISCLOSED, IN WHOLE OR PART, TO ANY UNAUTHORIZED PERSON OR ENTITY NOR REPRODUCED, TRANSFERRED OR INCORPORATED IN ANY OTHER PROJECT IN ANY MANNER WITHOUT THE EXPRESS WRITTEN CONSENT OF SAMTEC, INC.</p>		
	<p>520 PARK EAST BLVD, NEW ALBANY, IN 47150 PHONE: 812-944-6733 FAX: 812-948-5047 e-Mail info@SAMTEC.com code 55322</p>	
	<p>DO NOT SCALE DRAWING</p>	<p>DESCRIPTION: PLUG, SURFACE MOUNT, SMPM(F)</p>
<p>SHEET SCALE: 18:1</p>	<p>DWG. NO. SMPM-PS-P-XX-ST-SM-1</p>	<p>BY: ADAM H. 2/3/2020 SHEET 2 OF 3</p>

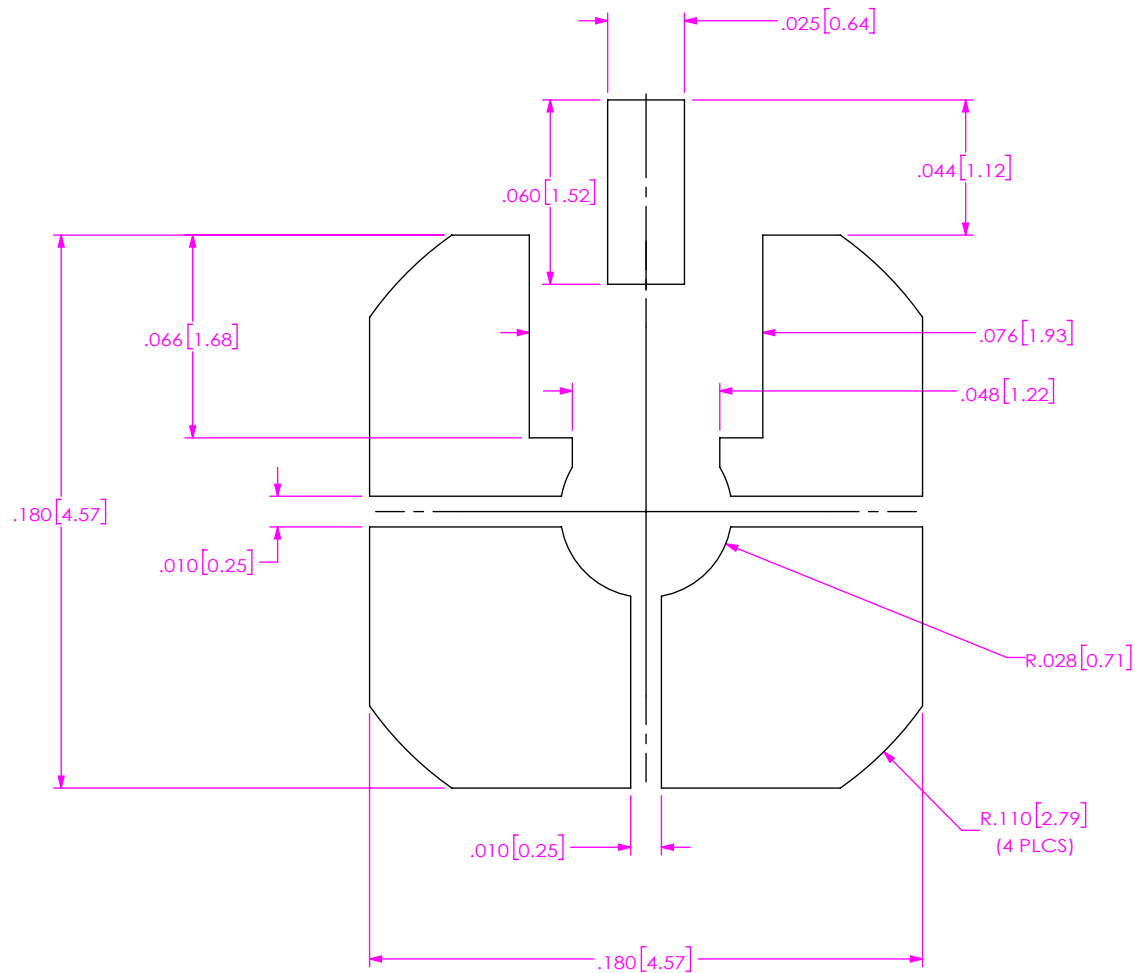

RECOMMENDED STENCIL APERTURE LAYOUT

NOTES:

1. RECOMMENDED STENCIL THICKNESS = .004".

<p>PROPRIETARY NOTE</p> <p>THIS DOCUMENT CONTAINS CONFIDENTIAL AND PROPRIETARY INFORMATION AND ALL DESIGN, MANUFACTURING, REPRODUCTION, USE, PATENT RIGHTS AND SALES RIGHTS ARE EXPRESSLY RESERVED BY SAMTEC, INC. THIS DOCUMENT SHALL NOT BE DISCLOSED, IN WHOLE OR PART, TO ANY UNAUTHORIZED PERSON OR ENTITY NOR REPRODUCED, TRANSFERRED OR INCORPORATED IN ANY OTHER PROJECT IN ANY MANNER WITHOUT THE EXPRESS WRITTEN CONSENT OF SAMTEC, INC.</p> <p>DO NOT SCALE DRAWING</p> <p>SHEET SCALE: 16:1</p>	 <p>520 PARK EAST BLVD, NEW ALBANY, IN 47150 PHONE: 812-944-6733 FAX: 812-948-5047 e-Mail info@SAMTEC.com code 55322</p>
	<p>DESCRIPTION: PLUG, SURFACE MOUNT, SMPM(F)</p>
	<p>DWG. NO. SMPM-PS-P-XX-ST-SM-1</p>
<p>BY: ADAM H. 2/3/2020 SHEET 3 OF 3</p>	