

DO NOT SCALE FROM THIS PRINT

DESIGNED & DIMENSIONED IN MILLIMETERS [INCHES]

TLH-XXX-X.XX-X-D-X-X-XX

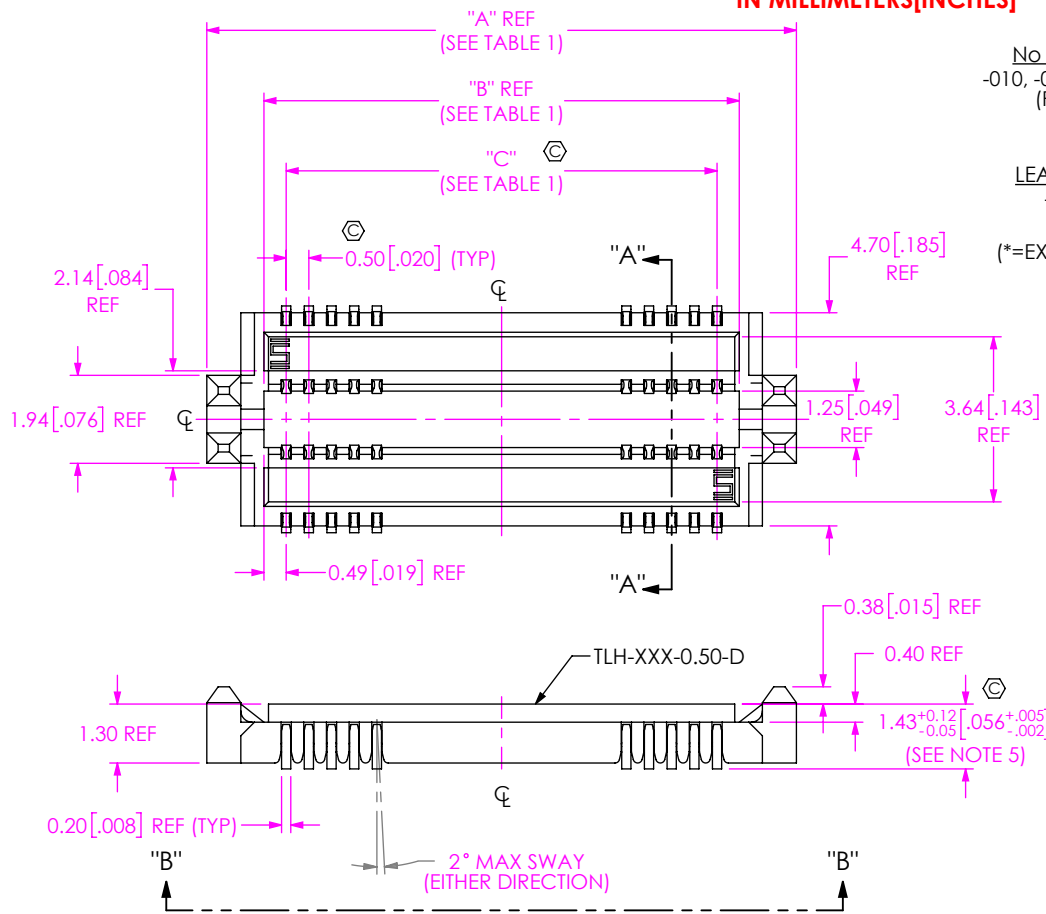

No. OF POSITIONS
-010, -020, -030, *-040 (PER ROW)

LEAD STYLE
-0.50

(* = EXISTING CUSTOMER ONLY)

TAPE & REEL (SEE NOTE 8 & 9)
-BLANK: TAPE & REEL
-FR: FULL REEL QTY TAPE & REEL

OPTION
-K: K-DOT (SEE FIG 2, SHT 2)

OPTION
-A: ALIGNMENT PIN (SEE FIG 3, SHT 3)

ROW SPECIFICATION
-D: DOUBLE ROW

PLATING SPECIFICATION
-G: 10μ" MIN Au IN CONTACT, 3μ" MIN Au ON TAIL

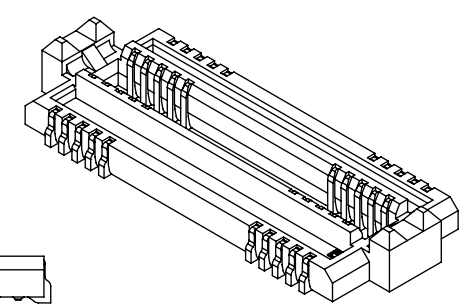

FIG 1
TLH-020-0.50-X-D SHOWN
(SOME CENTER FEATURES NOT SHOWN FOR CLARITY)

PATENT NUMBER
8,979,551

TABLE 1

NO OF POSITIONS	"A"	"B"	"C"	"D"	"E"	"F"
-010	8.000 [.3150]	5.480 [.2157]	4.50 [.177]	4.500 [.1772]	2.500 [.0984]	6.400 [.2520]
-020	13.000 [.5118]	10.480 [.4126]	9.50 [.374]	9.500 [.3740]	5.000 [.1969]	11.400 [.4488]
-030	18.000 [.7087]	15.480 [.6094]	14.50 [.571]	14.500 [.5709]	7.500 [.2953]	16.400 [.6457]
*-040	23.000 [.9055]	20.480 [.8063]	19.50 [.768]	19.500 [.7677]	10.000 [.3937]	21.400 [.8425]

(* = EXISTING CUSTOMER ONLY)

- NOTES:
- ⊗ REPRESENTS A CRITICAL DIMENSION.
 - MINIMUM PUSHOUT FORCE: 1.1N [.25 LB].
 - DELETED.
 - DELETED.
 - USE MEASURING FIXTURE AT-2617-802.
 - FOR APPLICATIONS REQUIRING TWO OR MORE CONNECTORS PER BOARD, CONTACT IPG@SAMTEC.COM.
 - TAPE & REEL IS STANDARD PACKAGING
 - ORDERS WILL BE PACKAGED ACCORDING TO THE SAMTEC PACKAGING EFFICIENCY STANDARDS (SPES) FOUND ON WWW.SAMTEC.COM.
 - ATTACH LABEL TO EACH REEL.

UNLESS OTHERWISE SPECIFIED, DIMENSIONS ARE IN MILLIMETERS.

TOLERANCES ARE:

DECIMALS	ANGLES
X.X: ±0.3 [.01]	2°
X.XX: ±0.13 [.005]	
X.XXX: ±0.051 [.0020]	

PROPRIETARY NOTE
THIS DOCUMENT CONTAINS CONFIDENTIAL AND PROPRIETARY INFORMATION AND ALL DESIGN, MANUFACTURING, REPRODUCTION, USE, PATENT RIGHTS AND SALES RIGHTS ARE EXPRESSLY RESERVED BY SAMTEC, INC. THIS DOCUMENT SHALL NOT BE DISCLOSED, IN WHOLE OR PART, TO ANY UNAUTHORIZED PERSON OR ENTITY NOR REPRODUCED, TRANSFERRED OR INCORPORATED IN ANY OTHER PROJECT IN ANY MANNER WITHOUT THE EXPRESS WRITTEN CONSENT OF SAMTEC, INC.

MATERIAL: DO NOT SCALE DRAWING SHEET SCALE: 6:1

INSULATOR: LCP, COLOR: BLACK
CONTACT: COPPER ALLOY

F:\DWG\MISC\MKTG\TLH-XXX-X.XX-X-D-X-X-MKT.SLDDRW

520 PARK EAST BLVD, NEW ALBANY, IN 47150
PHONE: 812-944-6733 FAX: 812-948-5047
e-Mail info@SAMTEC.com code 53322

DESCRIPTION: TLH TERMINAL ASSEMBLY

DWG. NO. TLH-XXX-X.XX-X-D-X-X-XX

BY: JERRY SU 10/25/2014 SHEET 1 OF 3

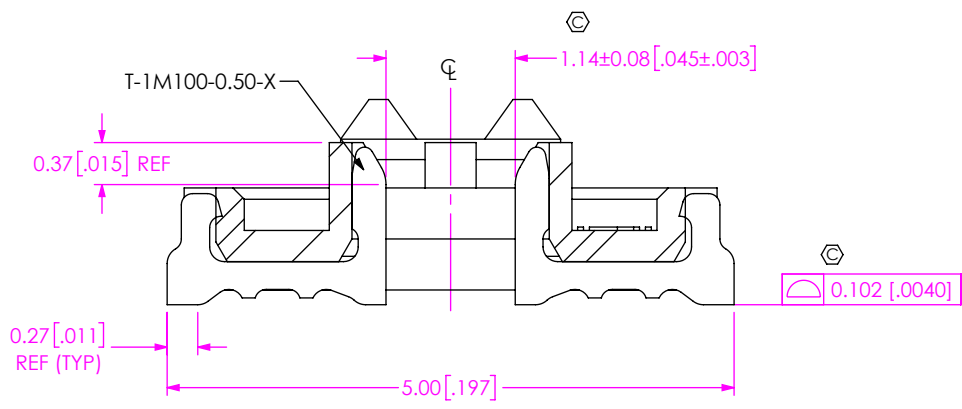

SECTION "A"-"A"
SCALE 15:1

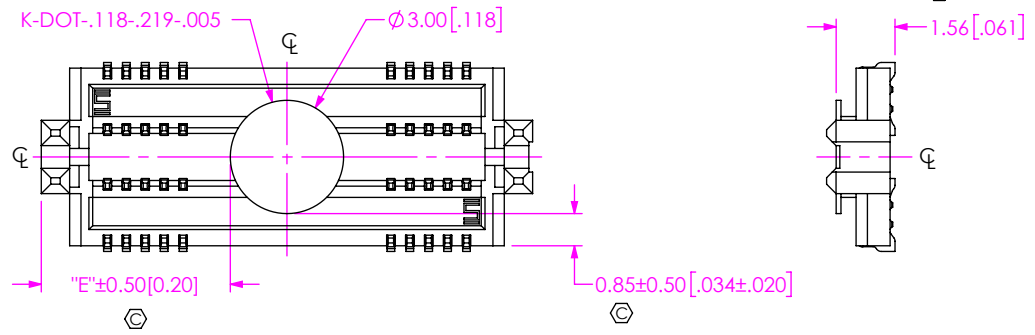
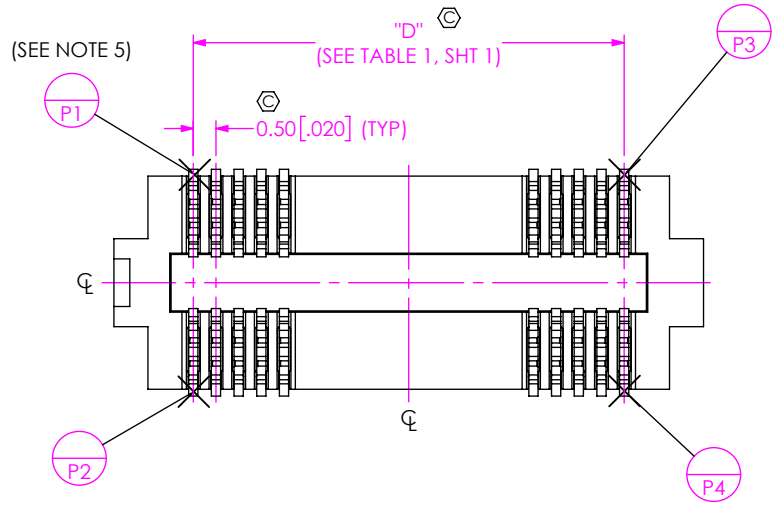

FIG 2
TLH-020-0.50-X-D-K SHOWN
(DIFFERENT AS SHOWN, OTHERWISE SAME AS FIG 1)
(SOME CENTER FEATURES NOT SHOWN FOR CLARITY)

PROPRIETARY NOTE
THIS DOCUMENT CONTAINS CONFIDENTIAL AND PROPRIETARY INFORMATION AND ALL DESIGN, MANUFACTURING, REPRODUCTION, USE, PATENT RIGHTS AND SALES RIGHTS ARE EXPRESSLY RESERVED BY SAMTEC, INC. THIS DOCUMENT SHALL NOT BE DISCLOSED, IN WHOLE OR PART, TO ANY UNAUTHORIZED PERSON OR ENTITY NOR REPRODUCED, TRANSFERRED OR INCORPORATED IN ANY OTHER PROJECT IN ANY MANNER WITHOUT THE EXPRESS WRITTEN CONSENT OF SAMTEC, INC.

DO NOT SCALE DRAWING
SHEET SCALE: 2:1



520 PARK EAST BLVD, NEW ALBANY, IN 47150
PHONE: 812-944-6733 FAX: 812-948-5047
e-Mail info@SAMTEC.com code 55322

DESCRIPTION:
TLH TERMINAL ASSEMBLY

DWG. NO.
TLH-XXX-X.XX-X-D-X-X-XX

BY: JERRY SU 10/25/2014 SHEET 2 OF 3

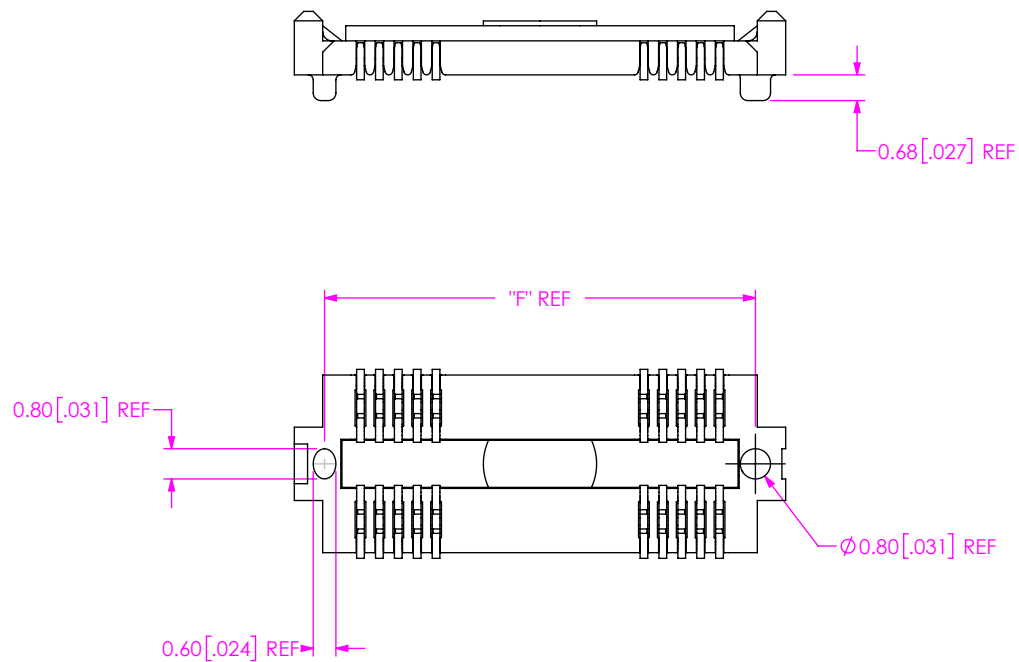

FIG 3: ALIGNMENT PIN DETAIL
 TLH-020-0.50-X-D-A-K SHOWN
 (SOME CENTER FEATURES NOT SHOWN FOR CLARITY)

• PROPRIETARY NOTE •
 THIS DOCUMENT CONTAINS CONFIDENTIAL AND PROPRIETARY INFORMATION AND ALL DESIGN, MANUFACTURING, REPRODUCTION, USE, PATENT RIGHTS AND SALES RIGHTS ARE EXPRESSLY RESERVED BY SAMTEC, INC. THIS DOCUMENT SHALL NOT BE DISCLOSED, IN WHOLE OR PART, TO ANY UNAUTHORIZED PERSON OR ENTITY NOR REPRODUCED, TRANSFERRED OR INCORPORATED IN ANY OTHER PROJECT IN ANY MANNER WITHOUT THE EXPRESS WRITTEN CONSENT OF SAMTEC, INC.

samtec
 520 PARK EAST BLVD, NEW ALBANY, IN 47150
 PHONE: 812-944-6733 FAX: 812-948-5047
 e-Mail info@SAMTEC.com code 55322

DO NOT SCALE DRAWING
 SHEET SCALE: 5:1

DESCRIPTION: TLH TERMINAL ASSEMBLY
 DWG. NO. TLH-XXX-X.XX-X-D-X-X-XX
 BY: JERRY SU 10/25/2014 SHEET 3 OF 3