

Interfacing and Integrating CPL modules

AN14-01 Guidelines for Designing with CPL (Compact Power Line) Rectifiers and Converters

Introduction

The CPL series of AC-DC power supplies and DC-DC converters provide users a high-density, high-efficiency power conversion solution. This application note guides the user on using these power supplies and converters in OEM systems. Three broad topics are discussed:

- How to evaluate and design-in a single CP module.
- How to evaluate and design-in a system consisting of multiple CP modules in a shelf
- Guidelines for a user wanting to design a custom shelf in their application

This application note complements the information provided in the detailed module data sheets. Note: This document is not a substitute for any existing data sheets. If there is a conflict between the information presented here and the individual data sheets, the data sheet information is binding.

Tools for the CP3500 rectifier

The latest planned addition of the family of rectifiers is the CP3500. At 3500 watts of output power capability it uses a different interfacing connector designed for higher power capacity. This rectifier cannot be used jointly with other power supplies of the platform, and it requires a different mating shelf, because of the difference in the mating connector.

A member of the new ABB Global-platform, the CP3500 includes a more comprehensive command set and an improved dual-redundant communications protocol. For example, the internal processor accepts both I²C lines directly. Therefore, the PCA9541 multiplexer, and its dedicated address, is no longer required.

Because of the many advanced features, the Graphical User Interface (GUI) for the CP3500 will be significantly different. It is important to note that the tools described below do not apply to the CP3500.

For example, a new interface module, the 1u_CP3500_interface, has been developed specifically for the CP3500 rectifier. New mating shelves are also currently being designed specifically for this rectifier.

Evaluation of a single module

The simplest method of evaluating the CP1800 through CP2725 power supplies is to use one of the Single Module CPL Interface cards along with the ABB Isolated Interface Adapter Kit. This is all that is needed to apply power, load the outputs and communicate with the module. Figure 1 shows a picture of an example test setup using this configuration.

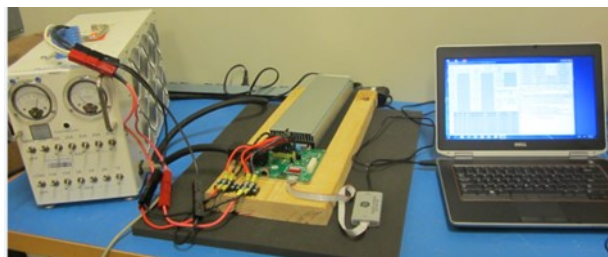

Figure 1 - Single module test setup using the Single Module CPL interface card

A more extensive evaluation can be done using one or more CPL modules in a standalone shelf (one of the variants of the ABB J85480 shelf). Besides the ability to process more power, functions such as current share, redundancy and hot swap can also be evaluated using this setup.

Single Unit Evaluation

For evaluating a single CP module the following ABB parts are required:

- Single Module CPL Interface card for rectifiers (Part# 150037482) or Single Module CPL Interface card for DC-DC Converters (Part# 150037483)

ABB Isolated Interface Adapter Kit (with USB Assembly and Ribbon Cable) – Part# 150036482

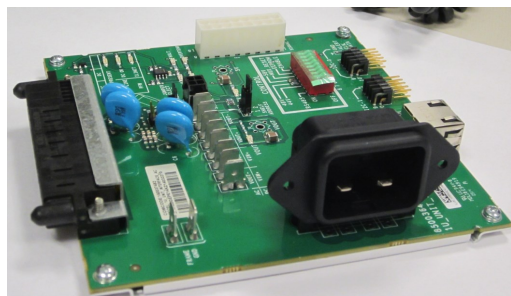

Figure 2 - Single Module CPL Interface card for rectifiers



Figure 3 - Single Module CPL interface card for DC-DC converters

Single Module CPL interface cards

These cards provide the interface to connect directly to the CP Power Supplies. The rectifier card utilizes an IEC320-C19 connector, rated at 20A, and fast-ON connectors for accessing the high power output of the rectifier. The DC-DC Converter card uses 0.250 fast-on terminations, rated at 35A each, for the DC input connections of the platform.

Both cards provide the following features;

- Visual indication of control signal states
- Control of the power supply
 - Output ON/OFF
 - Communications protocol selection
 - Address configuration for communications
 - Selectable output voltage settings
- Access to all signal pins
- Parallel ability of signal pins
- Multiplexer RESET
- Enable writing into the protected area of the EEPROM
- RS485 connector
- Dual I²C connectors designed to mate into individual ABB Interface Adapters

Two signal connectors are used to partition the signals between those referenced to Vout (-) and those referenced to Logic _GND. These two ground references are isolated from each other to meet Power Over the Ethernet (POE) isolation requirements.

Each connector has two rows of pins. The two rows are internally interconnected so that multiple modules could get paralleled by externally looping the connections between rows of the modules.

Connecting the Single Module CPL interface card

The single module CPL interface card has been designed to demonstrate the capability of the power supplies. As such, a number of important steps must be executed in sequence in order to ensure a safe and practical use of the interface card.

Always make sure that input power is not present on the interface card prior to the mating of any connector.

Loading the interface card

As seen in Figure 1 of the section on the evaluation of a single module, the power supply can be loaded down externally via 0.250 fast-on terminations. Make these connections first, before attempting to plug the interface card into the power supply.

Mating the power supply

It is imperative that the interface card be mated to the power supply with no input power present on the interface card. Although the mating connector on the interface card has guide pins, these are not sufficient to ensure arc-free mating of the power contacts during plug-in or extraction with power present.

Insert the mating connector into the power supply and ensure that the mated parts are flush with each other. That is, insert the power supply until positive repelling force is felt. The height of the connector on the interface card and of the power supply is flush with each other.

Make sure to rest the power supply and the interface card on a level surface. The engaging connector should not be used for mechanical support.

Alarm, Control and Test Connections

Status indicating LEDs provide alarm information and an eight position micro-switch provides control capability to the various functions such as :

- ON/OFF control,
- Margining the output voltage,
- Configuring the protocol pin to either RS485 mode or I²C,
- Multiplexer RESET.

Some additional features provided are ;

- Setting the communications address of the module through all possible combinations.
- Measuring output noise via ‘scope’ termination sockets of both the main output and 5V aux. (the connectors are not populated)

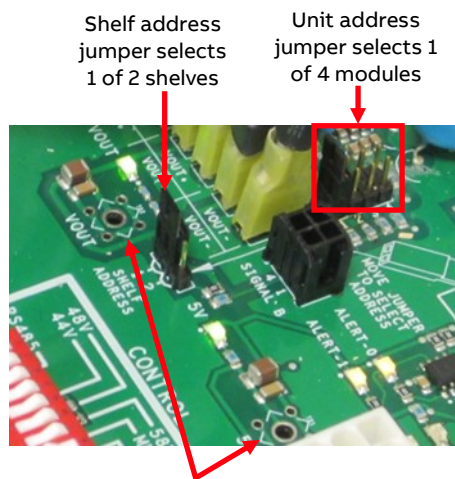

Scope connections – 54V and 5V

Figure 4 - Address Selection and Scope connection points

Dual set of Signal Pins provide the ability to parallel the signal pins across modules so that multiple modules could be evaluated by a single controller and back bias capability could be demonstrated.

- Output filtering duplicating the POE shelf provided circuit for additional EMI suppression.
- Connector pins for accessing the I²C signals for debug purposes. (the connectors are not populated).

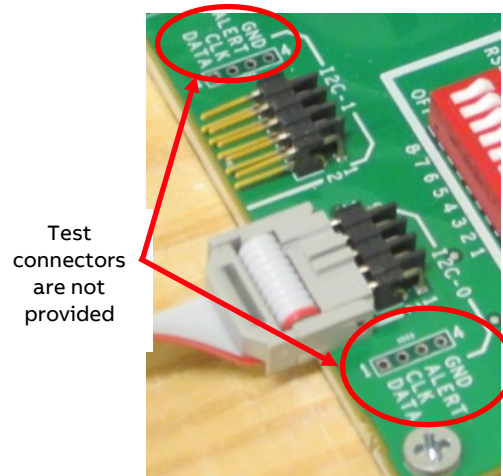

Figure 5 - Signal Connections

The orientation of the ribbon cable of the 10 position connector is important. The red wire should be located near position 1 as noted on the silkscreen of the module. The adapter is connected to I²C-0. Side 0 has control, by default and is a better position to start from because the multiplexer does not have to be exercised prior to the start of communications.

Power Connections

Once all terminations and default selections have been made, the power supply is ready to be powered up.

Rectifier Card

Connect high-line commercial AC input using the built-in IEC320-C20 connector through a suitable cord. Connect the cord to the interface card first, then use the plug for insertion into an appropriate receptacle. Make sure that you have plenty of room for viewing and changing features on the interface card.

DC-DC Converter Card

Both the Power Input and Power Output use 0.25 inch fast-on tabs which are clearly marked. For higher current capacity, each power supply connector blade is routed to two paralleled fast_ON tabs. Note that the DC-DC converter uses only a single power blade for carrying power output.

Connections are either input or output depending on the product

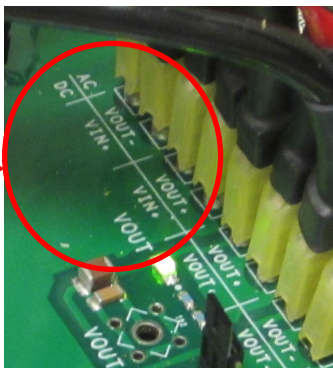

Figure 6 - Power Connections

Observe safety

The interface module has been designed to ensure that lethal voltages are not accessible. Do not remove the base plate of the interface module. It has been designed to mount on a solid surface with the four mounting screws and the height of the module lines up with the output connector of the power supply. Mating the two connectors is effortless.

Do not remove the cover from the module connector that is mated into the power supply. The cover shields lethal voltages on these connectors.

Do not remove protective shield

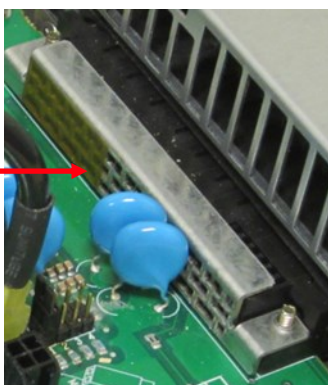

Figure 7 - Protective Shield

Turn-On sequence

Connect all components

Before applying input power to the interface card make all the necessary connections and verify that the terminations are safe and solid. Thorough engagement of the power supply connector is necessary to engage all pins and assure a controlled turn-on.

- Select module address
- Connect the ABB Interface Adapter
- Connect the input cable
- Plug the power supply into the power connector
- Connect loads (verify polarity of all connections)
- Connect signal connections if desired (see the table of pin assignments below)
- Set the selector switch **ENABLE** to **ON**, all other switches should be **OFF**
- Apply input power to the power supply.

If the ABB Interface Adapter is used, it should get connected to one of the USB ports of the 'host' emulation computer. The green LED of the translator should be continuously ON if the computer is operational.

Signal connector pin assignment

If multiple interface boards are used, they can be paralleled by interconnecting the pins of both connectors. Internally there is a short between the A and B columns shown above. (i.e. Ishare pin 3 is connected to Ishare pin 2.) For example, pins 9 – 16 of connector A could get tied to 1 – 8 of connector B.

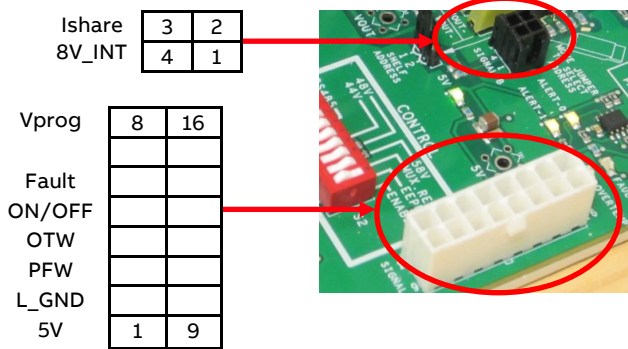

Figure 8 - Signal connector

LED Annunciation

The Single Module CPL interface card module has the following status/alarm LEDs,

- **UNIT PRESENT** – This indicator is ON when a module is physically plugged in and is operational.
- **LOW LINE/DC OK** – In rectifiers this indicator is ON when Input voltage is below 135V_{AC}. In PEMs this indicator shows that the output voltage is present and normal.

- **PWR FAIL WARNING/Ilimit** – This indicator shows **PFW** in rectifiers and **Current Limit** in PEMs.
- **FAULT** – This indicator is ON when the power supply issues a fault warning.
- **OVERTEMP** – This indicator is ON when the power supply gets into an over-temperature warning or shutdown condition.
- **ALERT-0/ALERT-1** – These LEDs are functional with I²C communications. The indicators are ON whenever the power supply requests service from the host controller.
- **Vout**, (near output fast-ON connectors) is lit when the 54V_{DC} output is ON.
- **5V**, to the right of the shelf address selector is ON when the 5V standby is ON.

Digital Power Insight™

Digital Power Insight™ (DPI) provides both a high level graphical user interface (gui) and a lower level command line interface (CLI) for communicating via I²C to the power supplies. These firmware tools emulate a ‘system controller’, accessing all available data and providing control of the module. Capabilities include;

- Reading of all status, alarm, and data registers
- ON/OFF control of the main output
- Output margining
- Changing the level of OV shutdown
- Fan speed control
- Configuration of OT and OC shutdown response
- Communications control from the two I²C ports
- Execution of a complete test sequence
- Automated monitoring and recording of events
- Writing/reading contents of the EEPROM
- Testing the OR’ing isolation feature

The DPI tools may be downloaded from ABB’s internet site.

abbpowerconversion.com

A window will appear asking whether to **run** or **save** the file. Save the .zip file into a designated directory. (c:\DPI is a suggestion) At the end of the download, double click on the .zip which should open the file structure and display an .msi file and a .docx file containing the user manual.

Double click on the .msi file. Click **run** or **continue** at each screen until the download is completed. The standard windows based download manager goes through a number of screens informing the user where the download will be configured.

Note that the configurator added a number of icons to the desk top. Each of these icons is a specific executable-program for a specific ABB product. One of the downloaded icons is the cpgui_l.exe program that starts the graphical user interface for the CPL product line.

Starting the Graphical User Interface (GUI)

The GUI is the same for both the CPL Shelf that is mated into a J85480 type shelf (described later in this document) and the Single Module CPL interface card connected to an individual module. Connect all the required components:

- Modules plugged into the interfaces and
- the ABB Interface Adapter connected between the interface and to one of the system controller emulating computer’s USB ports. The Green LED of the Interface Adapter should be lit to indicate that it is being powered by the USB port.

Power up the module and observe operation of the set of LED indicators on the interface cards. The two amber Alert LEDs of the interface card should lit up and the Interface Adapter’s LED should start blinking an Amber color. This is an indication by the module that it is available. Click on the cpgui_l.exe executable icon in order to communicate with the CPL power supplies. The GUI should appear as shown below.

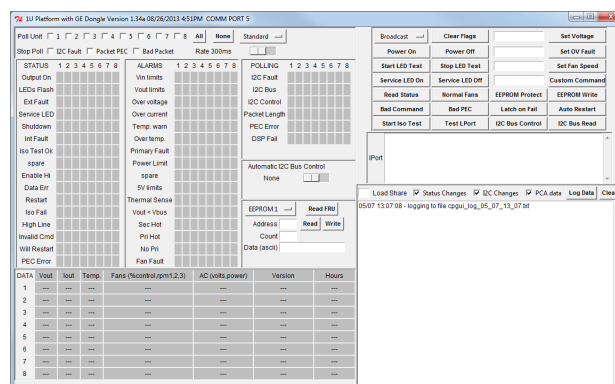

Figure 9 - CPGUI startup screen

If the screen does not appear after about a minute then the program likely had difficulty finding the ABB Interface Adapter. Attempt to reinsert the adapter to the USB port at least twice and then start the program again.

If the condition still persists, first verify that the dongle is recognized by the computer. Navigate to the **control panel, system, device manager, Port (COM& LPT)** and verify that the USB I²C Translator is identified as connected to a USB port.

One of the issues may be the bit capability of the computer, 32 bit or 64bit, and use of the appropriate driver for connecting the Adapter to the computer. The DPI User Manual has further instructions on loading the appropriate driver.

The DPI user manual includes the set of commands and their descriptions for communicating to the CPL modules.

System Level Testing

For s system level evaluation of multiple CPL modules, the following additional ABB parts are required (in addition to the specific modules).

- ABB J8540 Shelf (L20 through L40)
- CPL Shelf Module – Part # 150027074
- Interface cable to DC Shelf Part# CC109104460 / Interface cable to AC Shelf Part# CC848848960
- ABB Isolated Interface Adapter Kit (with USB Assembly and Ribbon Cable - Part# 150036482



Figure 10 -Test setup using a ABB J85480 shelf

ABB J85480 shelf architecture

ABB J85480 shelves, L20 through L30, cab each accommodate four modules in parallel. These shelves facilitate all termination requirements, addressing, and power busing.

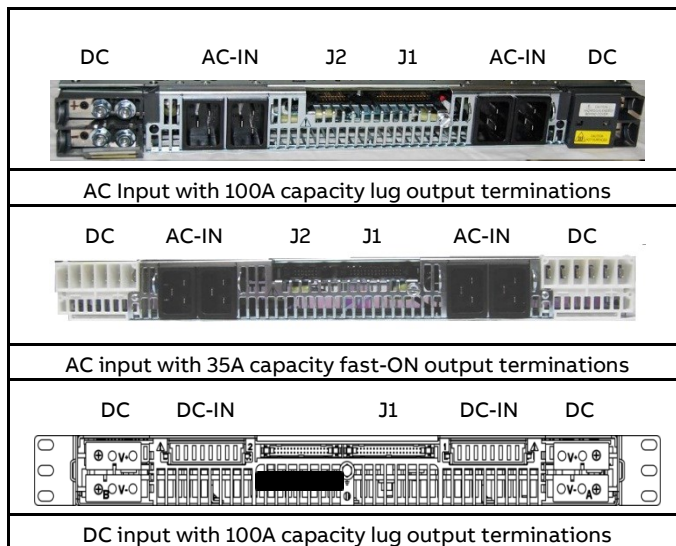

Figure 11 – Main versions of J85480

Input to the shelf is through IEC320 type connectors and the output is extracted either from lug or fast-ON terminations.

Signals for Status and Control are accessible to a system controller via the J1 connector. A custom cable mates J1 to the ABB developed CPL Shelf module. System level hardware based status and control can be emulated via LEDs and switches, or I²C based automated status reporting and control via firmware tools developed by ABB.

Connector J2 is utilized to inter-connect logic signals among daisy chained shelves.

System level features such as hot plug, power limit and current share can be quickly and easily evaluated using these shelves.

The CPL Shelf module

This module interacts with the user by displaying status information and enabling control of the various features of the CPL Units. It also provides the interface to the I²C communications capability of the CPL units for remote monitoring and control.

Status of the four CPL units in the shelf is displayed by various LEDs that are grouped for observation ease. This information is derived from the analog signals sent by the power supplies. Access to all hardware based control parameters is provided by a set toggle switches.

The following manual control features are provided;

- Visual indication of control signal states
- Control of the power supply
 - Output ON/OFF
 - Communications protocol selection
 - Selectable output voltage settings
- Multiplexer RESET
- Enable writing into protected area of the EEPROM
- RS485 connector
- Dual I²C connectors designed to mate into individual ABB Interface Adapters

CPL modules offer communication over two independent I²C lines. Users can verify the independent control capability over the two busses using the interface module. When dual control is desired, each of the two I²C lines is terminated into its own ABB isolated Interface Adapter. Each adapter then terminates upstream to its own computer, and each computer emulates an independent system controller. Demonstration of this capability is best performed using the graphical user interface (cp_gui) which offers canned commands for these functions.

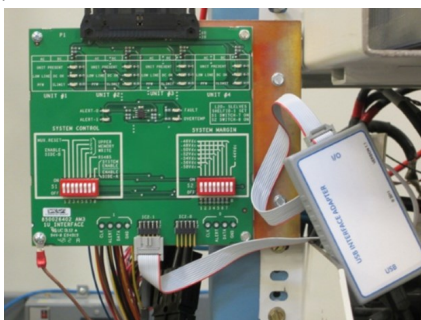

Figure 12 - CPL Shelf module connected to the ABB Adapter

Using the ABB J85480 shelves

Without a controller

The shelves can be ordered from the factory configured either with the main output ON all the time, or the main output controlled ON when the enable signal pin is connected to Logic_GRD.

Shelves are shipped from the factory with straps (jumpers) designed to connect the enable signal pins to Logic_GRD. These jumpers are either already on the J1 connector or they are included separately in a plastic bag. Below is a graphical representation of where the jumpers should be located.

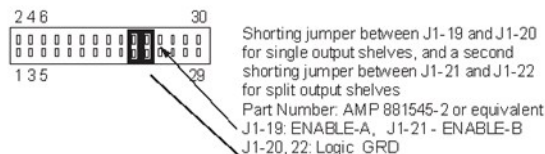

L20 – L30 type shelves

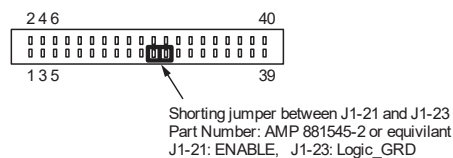

L1 – L14 type shelves

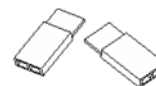

Shorting Jumper	
Plating	Part Number
0.000076	
0.000030	881545-2
Gold	

Jumper positioned into the J1 signal connector

Figure 13 - J1 Signal Connector Jumper positions

Operation with an external controller (J85480, L20 – L30 shelves)

A 6 foot interfacing cable (Fig. 14) with one end not terminated is offered to customers providing flexible termination means.

Part description	Part #
Control Interface cable	CC848854034



Figure 14 - Control cable plugged into the J1 connector

A ribbon cable (Fig. 15) is offered to connect two shelves of power supplies. This connector interconnects communications lines, current share, 5V_{DC} between shelves, and 8V_{INT}. Care should be taken to ensure that paralleled shelves are of the same type. i.e. split shelves should only be paralleled with other split shelves.

Part description	Part #
Shelf-to-shelf Interface cable	CC848848952



Figure 15 - Shelf-to-shelf ribbon cable of connector J2

The J85480 shelf data sheet provides additional details.

Using the CPL Shelf module

The CPL_Interface module is designed to demonstrate the capabilities of the CPL modules within the **J85480** type ABB CPL shelves. These capabilities are described separately either in the module data sheets, or in the **Communicating with the Compact Power Line (CPL) modules** user manual.

On one end of the interface module is a 40 position dual in-line connector that interfaces the module to the J1 connector of the CPL shelf. The other end the interface module has two 10 position connectors utilized to access two independent I²C communications lines. Each 10 position connector terminates via a ribbon cable to a **ABB USB Interface Adapter** whose function is to convert the I²C based protocol to USB terminations in computers. The computers function as ‘**system hosts**’, controlling and obtaining information from the modules via the I²C interface.

Two 8-position dip switches set operational functions and a number of LEDs display signaling states of the system.

Power for the Interface is derived from the +5V output of the power supply.

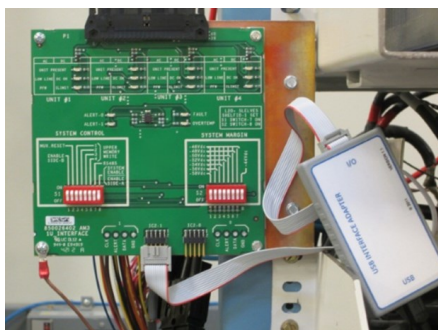

Figure 16 - The latest CPL Interface Module and USB Interface Adapter

Note orientation of the ribbon cable of the 10 position connector. The red wire should be located near position 1 as noted on the silkscreen of the module. Also, in the above picture the adapter is connected to I²C-1 and not I²C-0. To communicate from this position the power supply needs to be switched to side 1 because at default side 0 has control.

LED Annunciation

The top of the module shows four boxes, each one representing power supplies in the shelf under test. The three LEDs in each box are:

- **UNIT PRESENT** – This indicator is ON when a module is physically plugged in and at least one of the power supplies has input power (thus generating 5V_{DC} for the interface module).
- **LOW LINE/DC OK** – In rectifiers this indicator is ON when Input voltage is below 135V_{AC}. In PEMS this indicator shows that the output voltage is present and normal.
- **PWR FAIL WARNING/limit** – This indicator shows PFW in rectifiers and in **Current Limit** in PEMS.

Below the four sets of LED indicators there are two rows of LEDs, and these are;

- **FAULT** – This indicator is ON when one or more of the power supplies issues a fault warning.
- **OVERTEMP** – This indicator is ON when one or more of the power supplies gets into an over-temperature warning or shutdown condition.
- **ALERT-0/ALERT-1** – These LEDs are functional with I²C communications. The indicators are ON whenever the power supply requests service from the host controller.

Dip Switch Operation

There are two independent dip switches, one for **System Control** and the other for **System margin**.

The **System Margin** dip switch manually changes the output voltage of the power supply from its 54V_{DC} factory setting. Switch 1 ON margins the power supply output to 58V_{DC}. Switches 1 and 2 ON margin the power supply output to 56V_{DC} and so on. Switch 8 margins the power supply output to 44V_{DC} whenever it is ON, independent of the position of the other switches.

The **System Control** dip switch has the following functions;

- **MUX.RESET** – The PCA9541 includes a RESET function in case of a potential hang up. RESET reconfigures the device into its initial state. In addition, the device issues a set of reset commands to the downstream devices as well. For additional information please consult the application notes and data sheet for the PCA9541.
- **UPPER MEMORY WRITE 1-4** – Each of the four power supplies has an internal EEPROM. Setting these switches ON enables a *write* instruction into the upper ¼ of memory of each of the power supplies. Although this feature is available, it should be used with caution because a re-write will erase factory provided information. For further information see the individual module data sheets.
- **RS485** – When ON, sets the power supply to RS485. An controller should be connected through the interface module to communicate to the power supplies. When OFF, the modules are configured for I²C communications. The ABB_USB_ISO_Translator should get terminated into either one or both of the 10-position I²C connectors.
- **ENABLE side A/ENABLE side B** – These switches turn ON output power. ENABLE side A operates all power supplies in a single output shelf. In a split shelf ENABLE side A operates the leftmost two power supplies and ENABLE side B operates the rightmost two power supplies.

The CPGUI can be used for I²C evaluation of the system.

Digital Power Insight™

The ABB developed Digital Power Insight™ (DPI) provides both a high level graphical user interface (gui) and a lower level command line interface (CLI) for communicating via I²C to the power supplies. These firmware tools emulate a ‘system controller’, accessing all available data and providing control of the module.

Refer to the earlier section regarding evaluation unit level evaluation for more information.

Two shelf operation

Up to two shelves can be paralleled and communicated to when the shelf-to-shelf jumper ribbon cable interconnects the two shelves in the J2 connector slots. The interface module can only display the operational status of the four modules of the shelf that it is connected to. To display the status of the four power supplies in the second shelf a second interface module needs to be connected to the J1 connector of the second shelf.

Connections for i²C communications need to be made to only one of the two interface modules (in the two shelf arrangement) since communications are interconnected between the two shelves via the ribbon cable mated into the J2 connectors.

Guidelines on designing custom shelves and interfaces for the CPL modules

A few basic guidelines should be observed developing unique or customized interfaces to ensure a robust product.

- CPL offers both rectifiers and converters in the same form factor. These products are identical except for differences in symbols on the front panel and a keying tab on the rear of the cover. The keying tab is in a different location in converters to ensure that rectifiers do not get inserted into converter slots and vice versa. This mechanical feature is described in detail in the mechanical section of this document.



Figure 17 – Typical Faceplates

- High efficiency modules are further distinguished by a green colored area around the LEDs. Although currently only rectifiers have this distinguished feature, converters may also be identified in this fashion when higher efficiency models would be available. So the colored distinction may only be temporary and older vintage rectifiers may not have this color differential.



- CPL modules power capacities range from 1800 to 2725 watts. Mating connector ampacity must match the power capacity of the module.

Signal pin assignments

Only two status_indicator signal pins have different assignments between rectifiers and converters.

Pin	Rectifiers	Converters
A4	Power_fail_warning	Current_limit
D3	Power_capacity	Power_OK

Most signals are open source. They need to be pulled HI via a resistor to $V_{LOGIC} \leq 5V_{DC}$. When active LO, maximum $I_{DRAIN} \leq 10mA$, referenced to Logic_GRD. Exceptions are 8V_INT, Ishare, ON/OFF, Unit_ID, Shelf_ID, and Protocol; these signals are referenced to $V_{OUT}(-)$.

Power pins

Signal	Function
Vout (+)	Output power + side. Isolated from frame ground. May be connected to frame ground in non-POE applications.
Vout (-)	Output power – side. Isolated from frame ground. May be connected to frame ground in non-POE applications. Secondary control reference ¹ .
5Vaux	Provides 700mA of isolated standby power for system use. Interconnect among modules to achieve redundancy and maintain I ² C communications even if a module lacks input power.
Logic_GRD	Digital ground for signals, 5Vaux, and I ² C communications. Isolated from frame ground ($\leq 50V_{DC}$).

¹In split bus shelves Vout(-) is partitioned. Ishare, addressing, 8V_INT, protocol selection, ON/OFF (short pin) must get referenced to their own partitioned Vout(-).

Control signals referenced to Vout(-)

Signal	Function
ON/OFF	LMFB short pin ensuring last to make and first to break in hot plug applications.

Signal	Function																														
Unit_ID	<p>Sets unit address.</p> <p>A resistor connected between the Unit_ID pin and Vout (-).</p> <table border="1"> <thead> <tr> <th colspan="3"></th> <th colspan="2">I²C address</th> </tr> <tr> <th>Rectifier</th> <th>Resistor Value</th> <th>Nominal voltage</th> <th>A1</th> <th>A0</th> </tr> </thead> <tbody> <tr> <td>1</td> <td>30K</td> <td>2.477</td> <td>0</td> <td>0</td> </tr> <tr> <td>2</td> <td>14K</td> <td>1.925</td> <td>0</td> <td>1</td> </tr> <tr> <td>3</td> <td>6K</td> <td>1.243</td> <td>1</td> <td>0</td> </tr> <tr> <td>4</td> <td>2.5K</td> <td>0.654</td> <td>1</td> <td>1</td> </tr> </tbody> </table>				I ² C address		Rectifier	Resistor Value	Nominal voltage	A1	A0	1	30K	2.477	0	0	2	14K	1.925	0	1	3	6K	1.243	1	0	4	2.5K	0.654	1	1
			I ² C address																												
Rectifier	Resistor Value	Nominal voltage	A1	A0																											
1	30K	2.477	0	0																											
2	14K	1.925	0	1																											
3	6K	1.243	1	0																											
4	2.5K	0.654	1	1																											
Shelf_ID	<p>Sets shelf address for communications purposes.</p>																														
Protocol	The protocol pin should be a no-connect for either Analog or I ² C based control.																														

Control signals referenced to Logic_GRD

Signal	Function
Enable	<p>Hardware control of the main output. When connected to Logic_GRD the output is ON.</p> <p>Enable is not supported in RS485 mode.</p>
Margin	A resistor between Margin and Logic_GRD changes the output of the module. The J85480 L20-30 shelves include a margin resistor to set the output voltage to $54V_{DC}$.

Communications signals²

Signal	Function
8V_INT	reverse bias and power for shelf_ID, Reference Vout(-). Should be interconnected among modules that share Vout(-). Should not be used by the system.
Fault	May be interconnected among modules. Needs an external pull-up, HI-normal, LO - fault
PFW	May be interconnected among modules. Needs an external pull-up, HI-normal, LO-fault. Signal goes LO at least 3ms prior to the main output decreasing below regulation levels. This signal may be used as an Output_Good signal in addition to its pre-warning characteristics of imminent loss of output power.
OTW	Over Temperature Warning; May be interconnected among modules. Needs an external pull-up, HI-normal, LO - fault
SDA_0, SDA_1	Internally pulled-up of 5k-10KΩ to 3.3V _{DC} .
SCL_0, SCL_1	
Alert#_0, Alert#_1	Alert# can be triggered by the μC or the multiplexer. The Alert# from the multiplexer could be masked. HI-normal, LO active.
Power_cap	Indicates power delivery capability. Needs an external pull-up, HI - max power, LO-reduced power.
Module_present	Connected via a 500Ω resistor to Logic_GRD. Performs two functions; indicates module presence in the slot and enables write capability to the upper ¼ of memory of the EEPROM when the voltage level > 0.8Vdc on this signal pin.
Reset	Places the multiplexer into its default state. HI-normal, LO-reset activated
Ishare	Current share; interconnect between modules that are referenced to the same Vout (-). Do not connect any components to this pin. Note: This signal pin should not be used or be driven by the system.

²Unless otherwise noted referenced to Logic_GRD. External pull ups are normally terminated to ≤ 5Vdc

Compartment/shelf design

Step files are available to help locate latch and output connector positions. Module insertion needs to be accurate, without excessive play, in order to minimize connector arcing when plugging a module into a live backplane. Reliance on the connector guide pins is insufficient.

Below are guidelines that may help the design of a shelf for CPL.

Inverted module

The CPL modules are designed with the PWB inverted, hanging upside down, within the enclosure. The assumption of the inverted design, when mated into a system with a vertical backplane, is that the power system will be located on the bottom of the cabinet because it is one of the heaviest components that need to be located in a structurally sound location.

This inverted design provides a number of advantages,

- Airflow improvement through the module since the lower half of the back side is wide open for airflow.
- Minimal dust collection on the component side of the PWB since dust will collect on the bottom of the module.
- Components pull the PWB away from the enclosure minimizing the chance of electrical breakdowns.

In the concepts below it is assumed that the power system is located near the bottom of the rack because of its weight. The mating arrangement could either be a vertical backplane that interconnects blades above the power system or a horizontal module that provides mating from the top down. Of course, these are only two concepts and many others could also exist.

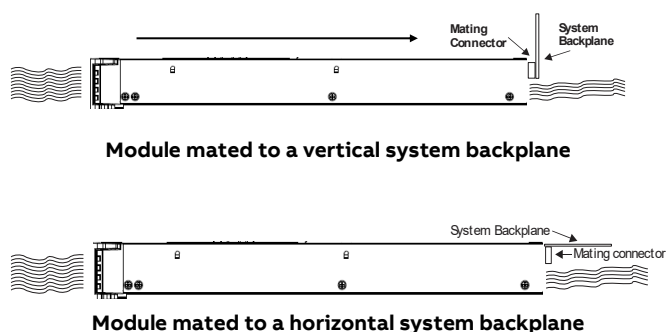

Figure 18 – Back plane alignments

Slot design

Slot dimensions are critical to ensure proper engagement of the module in the compartment. All dimensions are referenced from the right-most mounting tab of the mating connector located on the rear of the compartment. All dimension tolerances are ± 0.01 " (0.254mm).

- The 13.588" (345.1mm) dimension from the center of the mating connector mounting whole to the edge of the ejector tab secures the module in the compartment. This dimension is important to ensure that the connector is correctly engaged in its mate in the compartment.
- All module chassis covers have a notch that is designed to engage into a pin in the compartment whose mounting center is located 0.585" (14.86mm) from the center of the mating connector. This pin ensures that the correct module gets plugged into the compartment. That is, Power Entry Modules (PEMs) do not get inserted into rectifier compartments and vice versa. The first pin, assigned to PEMs, is located 1.44" (36.58mm) away from the right most mounting tab of the mating connector. The second pin, assigned to rectifiers, is located 0.60" (15.24mm) away from the second pin.
- Although only two pins are shown, ABB shelves have been designed to accept a third pin located in between the two pins shown below. This third pin is being assigned to the new CP3000 and CP3500 rectifiers currently being designed. The intent is to ensure that only modules with PwrBlade+™ connectors are plugged into these compartments. Note the pin locations for rectifiers and Power Entry DC/DC converter modules (PEMs). The location for these three pins is documented below.

- The width of the slot is 4.05" (102.9mm).
- The length of the ejector tab is 0.168" (4.267mm).

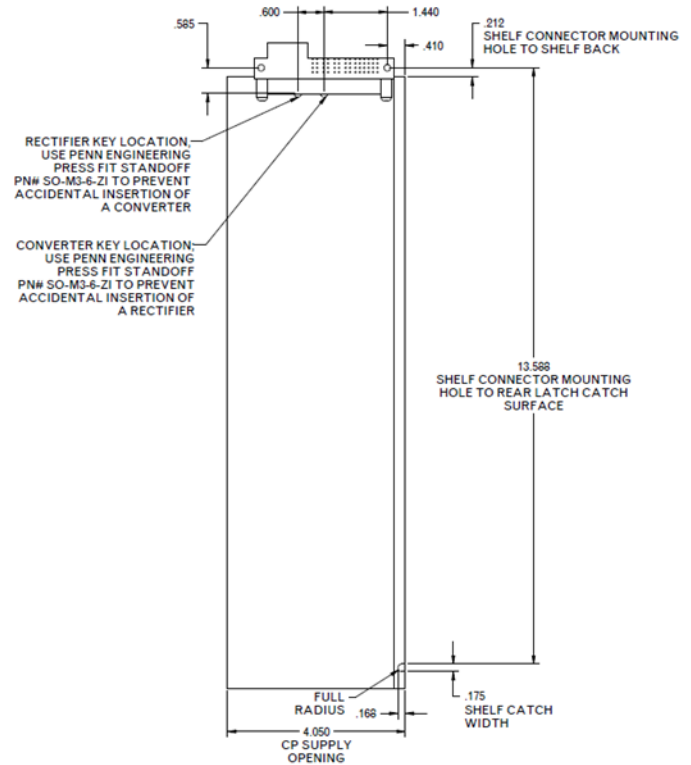

Figure 19 - Slot drawing

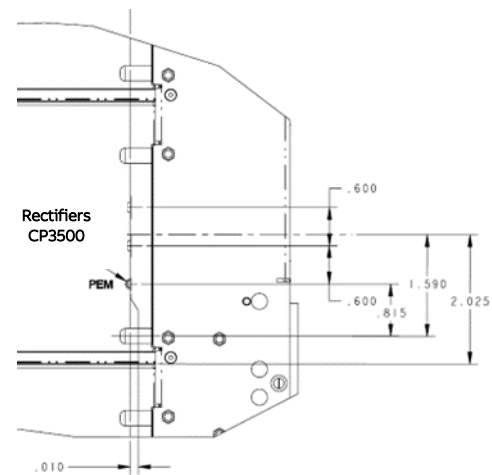

Figure 20 - Module type selector mechanical Key

Location of the mating connector and ejector tab

- The location of the bottom of the mating connector (the power supply PWB is mounted upside down) to the bottom of the compartment is 1.432" (36.37mm).
- The ejector tab must be positioned 0.069" (1.75mm) above the bottom of the compartment. This space is used by the modules to retain them vertically in the compartment. Note that ABB shelves do not have a top cover.
- The thickness of the ejector tab cannot exceed 0.120" (3.05mm) in order to enable the modules to slide into their cavity without obstruction. This cavity also ensures that modules do not get inserted inverted.

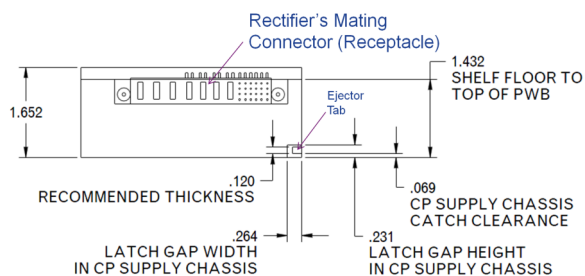

Figure 21 - View looking from the front without a module

Ejector tab design

- Below is a picture of the ejector tab design in ABB shelves. Although there are a variety of design approaches, at ABB the tab is spot welded in place. Although harder to manufacture, we believe that this is a more reliable approach.
- The ejector must withstand a 17 Nm(150 lb-in) force in the direction of ejection/injection.
- The ejector tab is rounded in order to gently guide the module ejection mechanism of the modules.



Figure 22 - View of tab in J series ABB shelf

Shelf dividers

A divider should be added between modules to provide a positive guide for hot insertion and extraction. Thickness of the divider should be at least 0.06" (1.52mm). The dividers should extend the full length of the module compartment.

Welded construction of the compartment dividers tends to provide a much stronger mechanical solution than other solutions such as riveting.

AC terminations

We recommend the use of mating connectors that provide for wire terminations on the input side. The advantages of this scheme are:

- Simpler backplane design
- Reduced EMI interference
- Maintains safety spacing without losing backplane real estate
- Ease of further EMI containment if necessary via twist pair leads or the addition of clip on beads



Figure 23 - Mating connector with input exiting flying leads

If termination on the backplane is unavoidable use the following guidelines;

- Position termination as close to the contact as possible.
- Keep input and output copper traces away from each other. Do not cross these traces on opposite planes.
- If crossing is unavoidable add ground planes between traces.

Output terminations

Two different solutions were implemented in ABB shelves. The first solution is a lug termination that can accept a single #4 wire sufficiently carrying 100 amperes. The second solution is three 0.250 fast-on terminations in parallel, each capable to carry 35 amperes. Fast-on's accommodate direct feeding of power to specific areas of the system, thus avoiding heavy current distribution. Or, alternatively, the three terminations can simply be paralleled into a single power plane.

Pictures of both the lug and fast-on implementations are shown on the first page of this document.

Pin Sequencing

The mating power connector in the compartment must provide the first-to-make-last-to-break power blade contact for the Frame_Ground pin of the input power feeder. The connector part numbers in the ABB module data sheets have this feature.

Any other sequencing requirements have already been taken care of on the module side.

EMC containment

Both common mode and differential mode output capacitance is recommended for conducted and radiated emissions containment. The circuit below is implemented in the ABB J85480 type shelves;

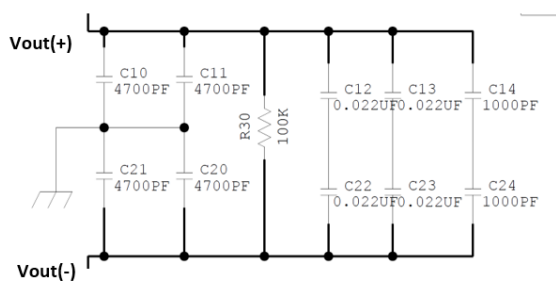

Change History (excludes grammar & clarifications)

Version	Date	Description of the change
2.0	08/04/2023	Updated as per ABB template



ABB

601 Shiloh Rd.
Plano, TX USA

abbpowerconversion.com

We reserve the right to make technical changes or modify the contents of this document without prior notice. With regard to purchase orders, the agreed particulars shall prevail. ABB does not accept any responsibility whatsoever for potential errors or possible lack of information in this document.

We reserve all rights in this document and in the subject matter and illustrations contained therein. Any reproduction, disclosure to third parties or utilization of its contents – in whole or in parts – is forbidden without prior written consent of ABB.

Copyright© 2023 ABB
All rights reserved.