

CHT-NMOS80XX DATASHEET

Version: 2.9
15-Feb-21
(Last Modification Date)

High-Temperature, 80V Power NMOSFET

General description

The CHT-NMOS80XX is a high voltage N-channel mid-power MOSFET family designed to achieve high performance in an extremely wide temperature range. Typical operation temperatures go from -55°C to 225°C.

CHT-NMOS80XX parts sustain the highest temperatures while keeping leakage current low.

Typical Markets

- Well logging,
- Oil & Gas,
- Aeronautics & aerospace,
- Automotive.

Features

- Specified from -55 to +225°C (Tj)
- Drain voltage up to 80V
- Typical output current (@ 25°C)
 - CHT-NMOS-8005: 7.5A
 - CHT-NMOS-8010: 13.5A
- R_{DSon}
 - CHT-NMOS-8005: 0.99Ω @ 225°C
 - CHT-NMOS-8010: 0.44Ω @ 225°C
- VGS = 0V to +5V
- Reverse ESD diode between gate and source.
- Validated at 225°C for 1000 hours (and still on-going)
- Available in TO254 package.

Package configurations¹

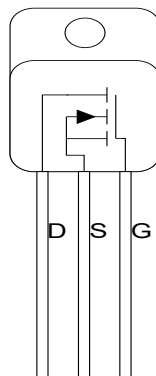

TO254 (Top view) (case floating)

¹ Other packages available upon request.

Absolute Maximum Ratings

Gate-to-Source voltage V_{GS}	-0.5V to 5.5V	
Pulsed drain current I_{DS} ($T_{pulse} = 1\mu s$)		
CHT-NMOS8005:	8.5A @	$T_j = -55^\circ C$
	7.5A @	$T_j = 25^\circ C$
	5A @	$T_j = 225^\circ C$
CHT-NMOS8010:	16A @	$T_j = -55^\circ C$
	13.5A @	$T_j = 25^\circ C$
	9A @	$T_j = 225^\circ C$
Power dissipation(with heat sink) $T_c = 25^\circ C$		
CHT-NMOS8005:	45W	
CHT-NMOS8010:	45W	
DC drain current ($V_{GS} = 5V$)		
CHT-NMOS8005:	5A	
CHT-NMOS8010:	10A	
Junction temperature T_j	300°C	

ESD Rating (expected)

Human Body Model (expected)	2kV
-----------------------------	-----

Operating Conditions

Gate-to-Source voltage V_{GS}	0V to 5V
Drain-to-Source voltage V_{DS}	0V to 80V
DC drain current ($V_{GS} = 5V$)($T_C = 175^\circ C$)	
CHT-NMOS8005:	3.3A
CHT-NMOS8010:	4.5A
Power dissipation $T_c = 25^\circ C$	40W
Junction temperature	-55°C to +225°C

Stresses above those listed in "Absolute Maximum Ratings" may cause permanent damage to the device. This is a stress only rating and operation of the device at these or any other conditions above those indicated in the operational sections of this specification is not implied. Frequent or extended exposure to absolute maximum rating conditions or above may affect device reliability.

Electrical characteristics of CHT-NMOS8005

DC Characteristics

Unless otherwise stated, $T_j = 25^\circ\text{C}$. **Bold** figures point out values valid over the whole temperature range ($T_j = -55^\circ\text{C}$ to $+225^\circ\text{C}$).

Parameter	Symbol	Condition	Min	Typ	Max	Unit
Threshold voltage	V_{TH}	$V_{DS} = 50\text{mV}$	1	1.6	1.9	V
Drain cut-off current	I_{DSS}	$V_{GS} = 0\text{V}$, $V_{DS} = 80\text{V}$, $T_j = 25^\circ\text{C}$		10		nA
		$V_{GS} = 0\text{V}$, $V_{DS} = 80\text{V}$, $T_j = 225^\circ\text{C}$		25		uA
Gate leakage current ¹	I_{GSS}	$V_{GS} = 5\text{V}$, $V_{DS} = 50\text{mV}$, $T_j = 25^\circ\text{C}$		19		nA
		$V_{GS} = 5\text{V}$, $V_{DS} = 50\text{mV}$, $T_j = 225^\circ\text{C}$		0.16		uA
Static drain-to-source resistance	$R_{DS(on)}$	$V_{GS} = 5\text{V}$, $V_{DS} = 50\text{mV}$, $T_j = -55^\circ\text{C}$		0.37		Ω
		$V_{GS} = 5\text{V}$, $V_{DS} = 50\text{mV}$, $T_j = 25^\circ\text{C}$		0.48		Ω
		$V_{GS} = 5\text{V}$, $V_{DS} = 50\text{mV}$, $T_j = -225^\circ\text{C}$		0.99		Ω
Breakdown drain-to-source voltage ²	V_{BRDS}	$V_{GS} = 0\text{V}$	80			V

Dynamic Characteristics

Unless otherwise stated, $T_j = 25^\circ\text{C}$. **Bold** figures point out values valid over the whole temperature range ($T_j = -55^\circ\text{C}$ to $+225^\circ\text{C}$).

Parameter	Symbol	Condition	Min	Typ	Max	Unit
Input capacitance	C_{ISS}	$V_{GS} = 0V_{DC}$, $V_{DS} = 25V_{DC}$		410		pF
Output capacitance	C_{OSS}	$V_{GS} = 0V_{DC}$, $V_{DS} = 25V_{DC}$		103		pF
Feedback capacitance	C_{RSS}	$V_{GS} = 0V_{DC}$, $V_{DS} = 25V_{DC}$		22		pF
Gate to Source Charge	Q_{GS}	$V_{GS} = [0 \rightarrow 5]\text{V}$; $V_D = 80\text{V}$		5.1		nC

Switching Characteristics

Unless otherwise stated, $T_j = 25^\circ\text{C}$. **Bold** figures point out values valid over the whole temperature range ($T_j = -55^\circ\text{C}$ to $+225^\circ\text{C}$).

Parameter	Symbol	Condition	Min	Typ	Max	Unit
Turn-on delay time	$t_{d(ON)}$	$V_{DS} = 40\text{V}$, $V_{GS} = 5\text{V}$ 1 μs pulse		30		ns
Rise time	t_r	$V_{DS} = 40\text{V}$, $V_{GS} = 5\text{V}$ 1 μs pulse		52		ns
Turn-off delay time	$t_{d(OFF)}$	$V_{DS} = 40\text{V}$, $V_{GS} = 5\text{V}$ 1 μs pulse		60		ns
Fall time	t_f	$V_{DS} = 40\text{V}$, $V_{GS} = 5\text{V}$ 1 μs pulse		74		ns
Drain current	I_D	$V_{DS} = 80\text{V}$, $V_{GS} = 5\text{V}$ 1 μs pulse, $T_j = -55^\circ\text{C}$		8.5		A
		$V_{DS} = 80\text{V}$, $V_{GS} = 5\text{V}$ 1 μs pulse, $T_j = 25^\circ\text{C}$		7.5		A
		$V_{DS} = 80\text{V}$, $V_{GS} = 5\text{V}$ 1 μs pulse, $T_j = 225^\circ\text{C}$		5		A

Thermal Characteristics

Parameter	Symbol	Condition	Min	Typ	Max	Unit
Junction to case thermal resistance	Θ_{JC}	TO-254 package		5		$^\circ\text{C/W}$

¹ Includes ESD diode leakage current.

² Voltage for which the cut-off current evolution versus V_{DS} becomes exponential.

Electrical characteristics of CHT-NMOS8010

DC Characteristics

Unless otherwise stated, $T_j = 25^\circ\text{C}$. **Bold** figures point out values valid over the whole temperature range ($T_j = -55^\circ\text{C}$ to $+225^\circ\text{C}$).

Parameter	Symbol	Condition	Min	Typ	Max	Unit
Threshold voltage	V_{TH}	$V_{DS} = 50\text{mV}$	1	1.6	1.9	V
Drain cut-off current	I_{DSS}	$V_{GS} = 0\text{V}$, $V_{DS} = 80\text{V}$, $T_j = 25^\circ\text{C}$		20		nA
		$V_{GS} = 0\text{V}$, $V_{DS} = 80\text{V}$, $T_j = 225^\circ\text{C}$		50		uA
Gate leakage current ³	I_{GSS}	$V_{GS} = 5\text{V}$, $V_{DS} = 50\text{mV}$, $T_j = 25^\circ\text{C}$		100		pA
		$V_{GS} = 5\text{V}$, $V_{DS} = 50\text{mV}$, $T_j = 225^\circ\text{C}$		390		nA
Static drain-to-source resistance	R_{Dson}	$V_{GS} = 5\text{V}$, $V_{DS} = 50\text{mV}$, $T_j = -55^\circ\text{C}$		0.18		Ω
		$V_{GS} = 5\text{V}$, $V_{DS} = 50\text{mV}$, $T_j = 25^\circ\text{C}$		0.24		Ω
		$V_{GS} = 5\text{V}$, $V_{DS} = 50\text{mV}$, $T_j = -225^\circ\text{C}$		0.46		Ω
Breakdown drain-to-source voltage ⁴	V_{BRDS}	$V_{GS} = 0\text{V}$	80			V

Dynamic Characteristics

Unless otherwise stated, $T_j = 25^\circ\text{C}$. **Bold** figures point out values valid over the whole temperature range ($T_j = -55^\circ\text{C}$ to $+225^\circ\text{C}$).

Parameter	Symbol	Condition	Min	Typ	Max	Unit
Input capacitance	C_{ISS}	$V_{GS} = 0V_{DC}$, $V_{DS} = 25V_{DC}$		850		pF
Output capacitance	C_{OSS}	$V_{GS} = 0V_{DC}$, $V_{DS} = 25V_{DC}$		205		pF
Feedback capacitance	C_{RSS}	$V_{GS} = 0V_{DC}$, $V_{DS} = 25V_{DC}$		45		pF
Gate to Source Charge	Q_{GS}	$V_{GS} = [0 \rightarrow 5]\text{V}$; $V_D = 80\text{V}$		10.2		nC

Switching Characteristics

Unless otherwise stated, $T_j = 25^\circ\text{C}$. **Bold** figures point out values valid over the whole temperature range ($T_j = -55^\circ\text{C}$ to $+225^\circ\text{C}$).

Parameter	Symbol	Condition	Min	Typ	Max	Unit
Turn-on delay time	$t_{d(ON)}$	$V_{DS} = 40\text{V}$, $V_{GS} = 5\text{V}$ 1 μs pulse		38		ns
Rise time	t_r	$V_{DS} = 40\text{V}$, $V_{GS} = 5\text{V}$ 1 μs pulse		72		ns
Turn-off delay time	$t_{d(OFF)}$	$V_{DS} = 40\text{V}$, $V_{GS} = 5\text{V}$ 1 μs pulse		102		ns
Fall time	t_f	$V_{DS} = 40\text{V}$, $V_{GS} = 5\text{V}$ 1 μs pulse		79		ns
Drain current	I_D	$V_{DS} = 80\text{V}$, $V_{GS} = 5\text{V}$ 1 μs pulse, $T_j = -55^\circ\text{C}$		16		A
		$V_{DS} = 80\text{V}$, $V_{GS} = 5\text{V}$ 1 μs pulse, $T_j = 25^\circ\text{C}$		13.5		A
		$V_{DS} = 80\text{V}$, $V_{GS} = 5\text{V}$ 1 μs pulse, $T_j = 225^\circ\text{C}$		9		A

Thermal Characteristics

Parameter	Symbol	Condition	Min	Typ	Max	Unit
Junction to case thermal resistance	Θ_{JC}	TO-254 package		5		$^\circ\text{C/W}$

³ Includes ESD diode leakage current.

⁴ Voltage for which the cut-off current evolution versus V_{DS} becomes exponential.

Typical Performance Characteristics of CHT-NMOS8005

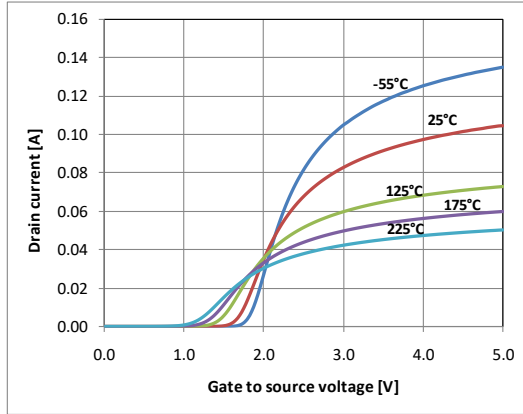

Drain current vs. gate voltage ($V_D = 50\text{mV}$).

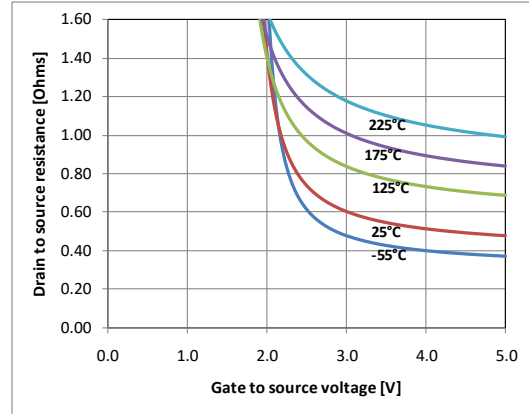

Drain-source resistance vs. gate voltage ($V_D = 50\text{mV}$)

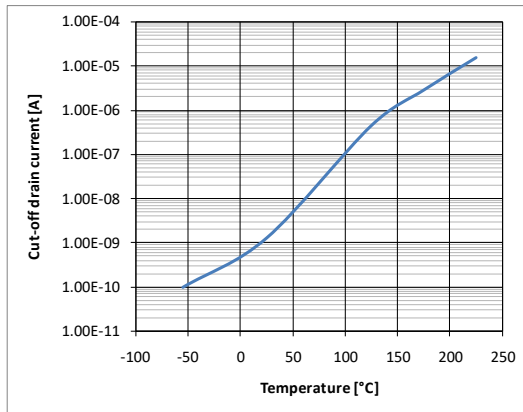

Cut-off current vs. junction temperature
 ($V_G = 0\text{V}$, $V_D = 80\text{V}$).

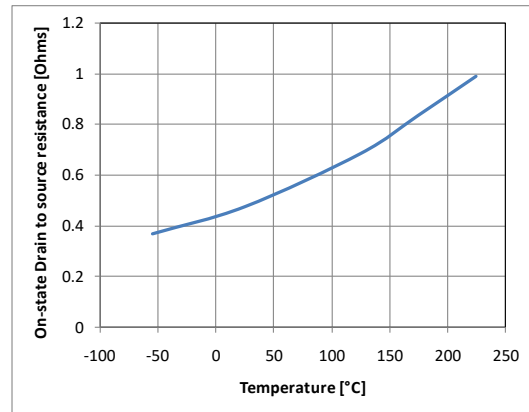

On-state drain source resistance vs. junction temperature
 ($V_G = 5\text{V}$, $V_D = 50\text{mV}$).

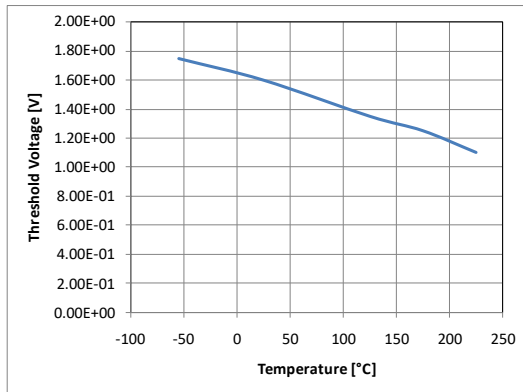

Threshold voltage vs. junction temperature.

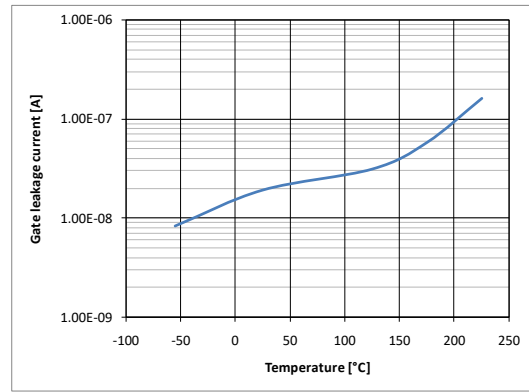

Gate and ESD diode leakage current vs. junction temperature
 ($V_G = 5\text{V}$, $V_D = 50\text{mV}$).

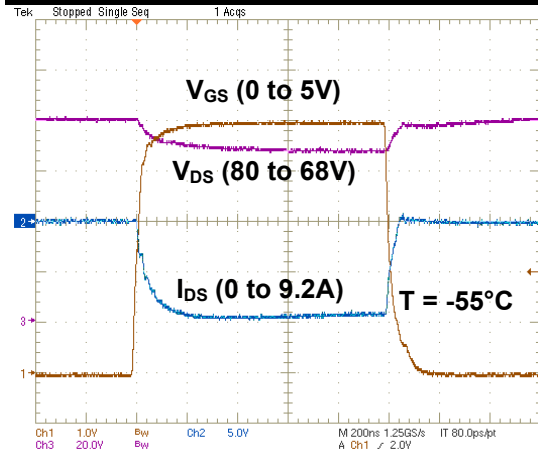

Maximum drain current pulse test ($T_j = -55^\circ\text{C}$).

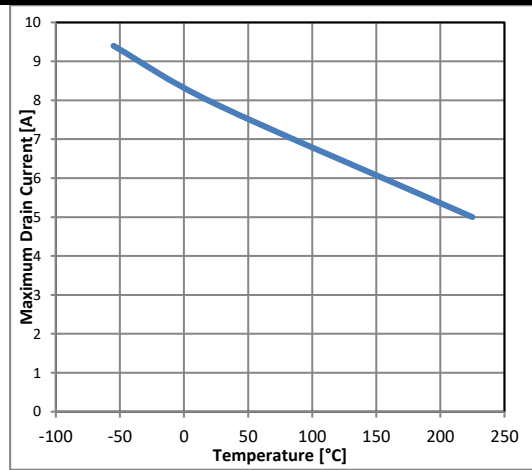

Peak drain current vs. temperature ($V_G=5\text{V}$, $V_D=80\text{V}$).

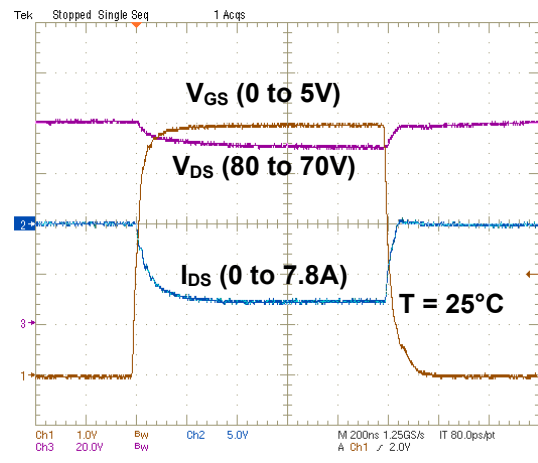

Maximum drain current pulse test ($T_j = 25^\circ\text{C}$).

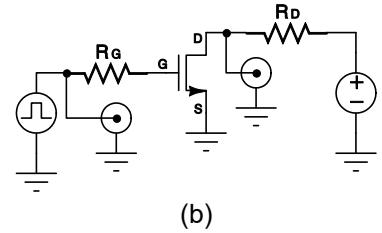
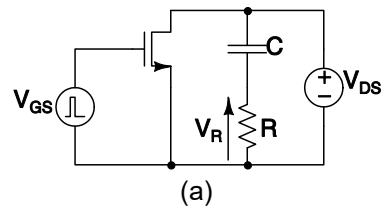

(a) I_D^{MAX} measurement scheme $R=1\Omega$, $C=100\mu\text{F}$, Compliance ($V_{DS}=80\text{V}$)= 100mA (b) Timing measurement scheme $R_G=0\Omega$, $R_D=15\Omega$, $V_{DS}=40\text{V}$.

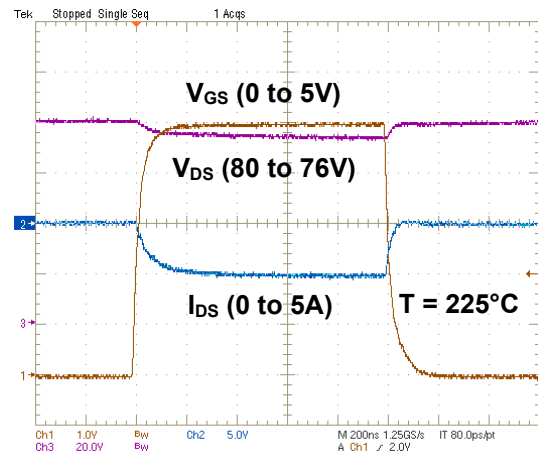

Maximum drain current pulse test ($T_j = 225^\circ\text{C}$).

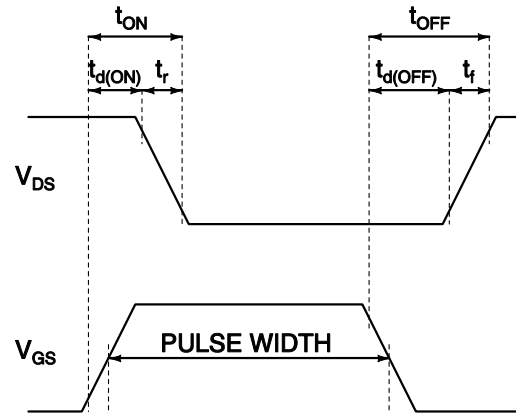

Timing definition diagram.

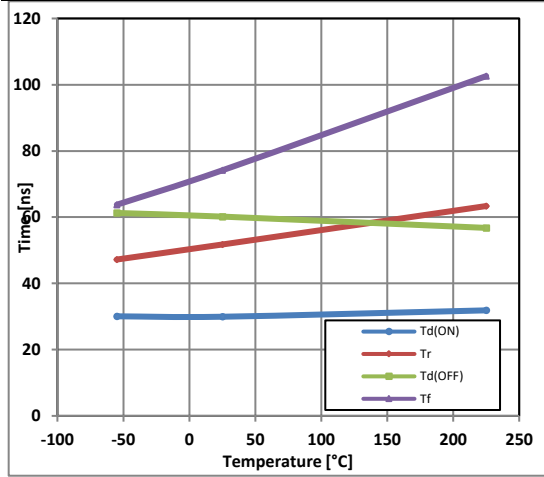

Timing parameters versus temperature.

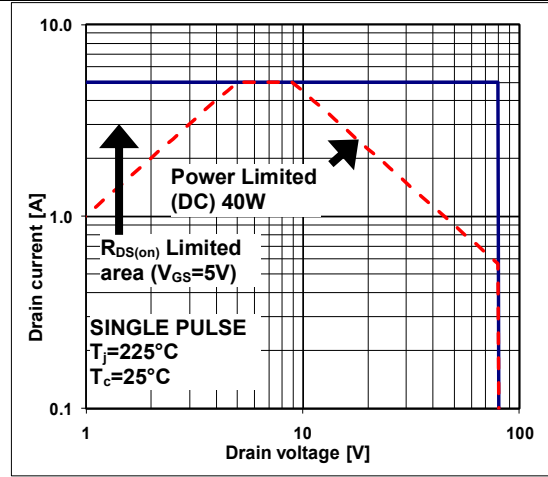

Forward bias safe operating area.

Typical Performance Characteristics of CHT-NMOS8010

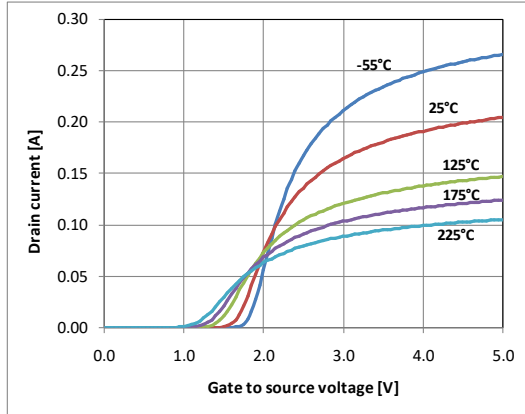
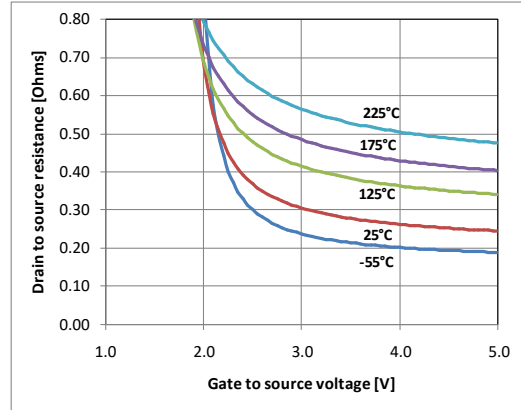
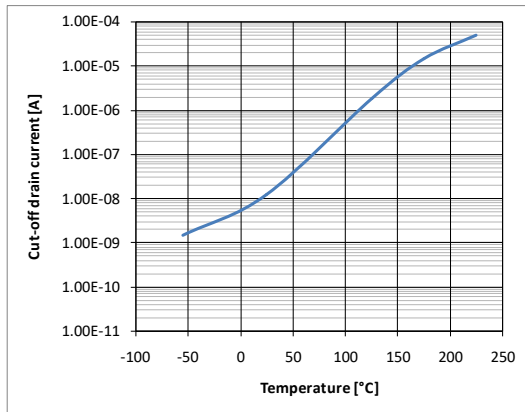
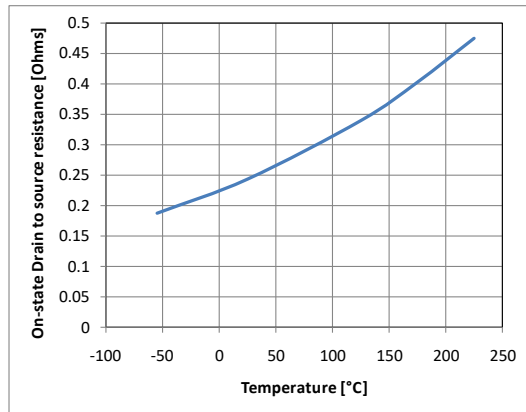
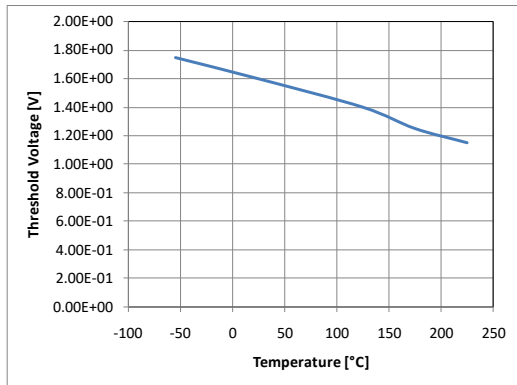
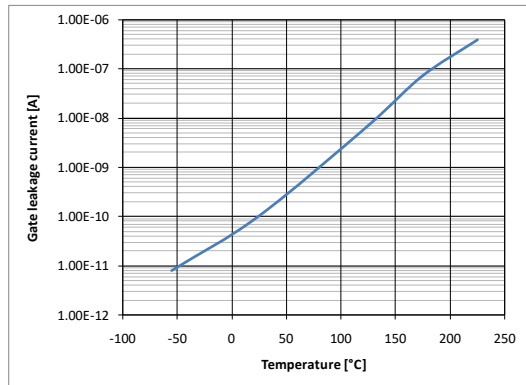

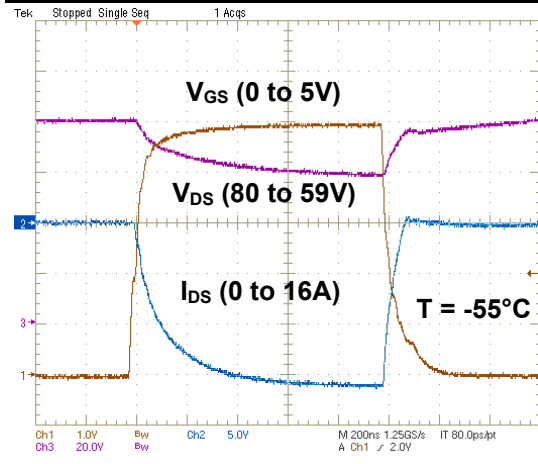
Drain current vs. gate voltage ($V_D = 50mV$).

Drain-source resistance vs. gate voltage ($V_D=50mV$).

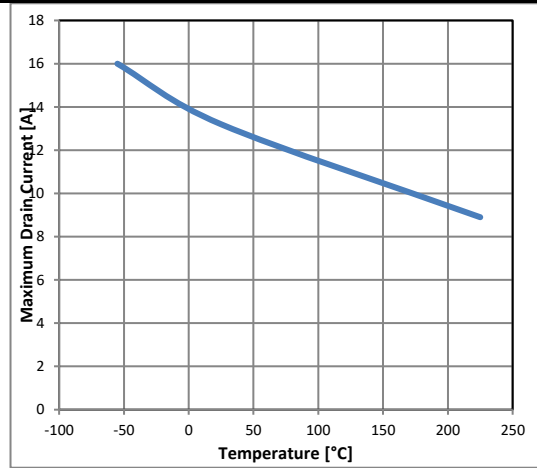
Cut-off current vs. junction temperature ($V_G=0V, V_D=80V$).

On-state drain source resistance vs. junction temperature ($V_G=5V, V_D=50mV$).

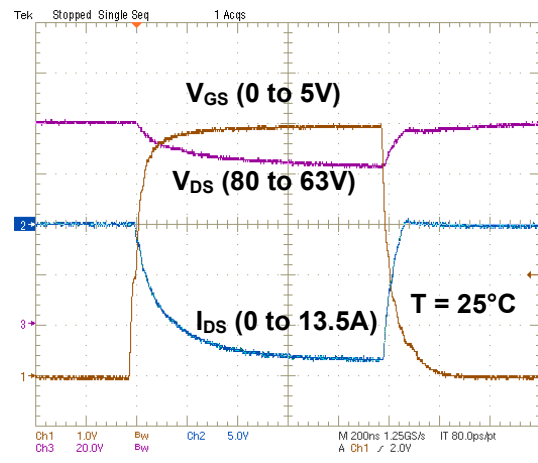
Threshold voltage vs. junction temperature.

Gate and ESD diode leakage current vs. junction temperature ($V_G=5V, V_D=50mV$).



Maximum drain current pulse test ($T_j = -55^\circ\text{C}$).



Peak drain current vs. temperature ($V_G=5\text{V}$, $V_D=80\text{V}$).



Maximum drain current pulse test ($T_j = 25^\circ\text{C}$).

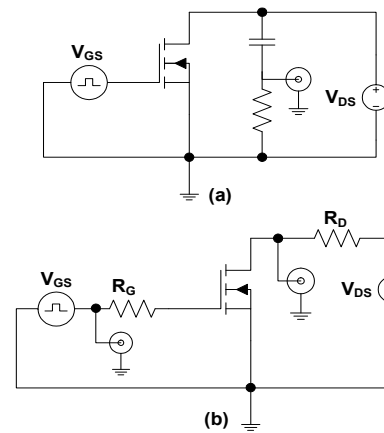

(a) I_D^{MAX} measurement scheme $R=1\Omega$, $C=100\mu\text{F}$, Compliance ($V_{DS}=80\text{V}$)= 100mA (b) Timing measurement scheme $R_G=0\Omega$, $R_D=15\Omega$, $V_{DS}=40\text{V}$.

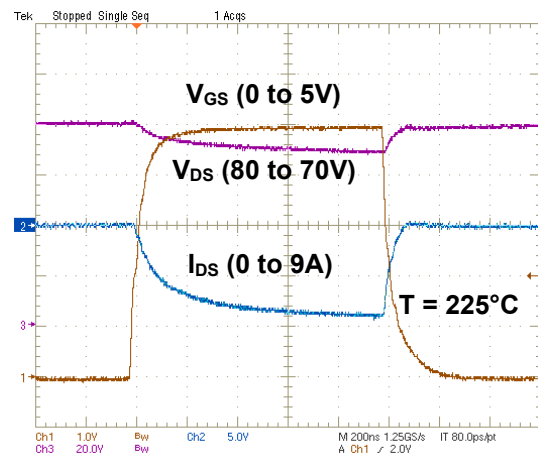

Maximum drain current pulse test ($T_j = 225^\circ\text{C}$).

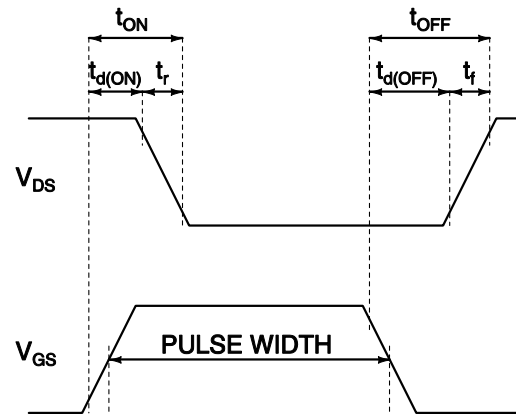

Timing definition diagram.

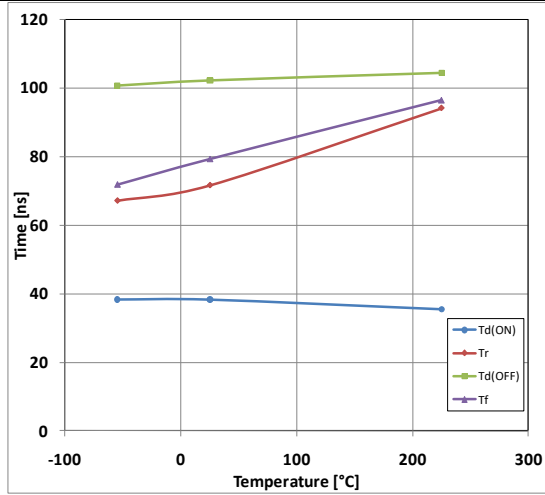

Timing parameters versus temperature.

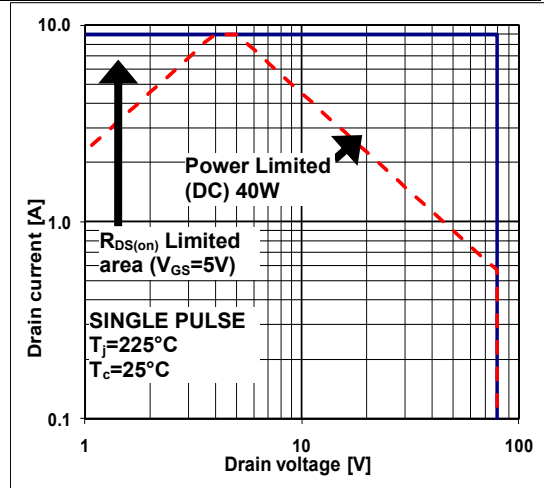

Forward bias safe operating area.



Package Dimensions

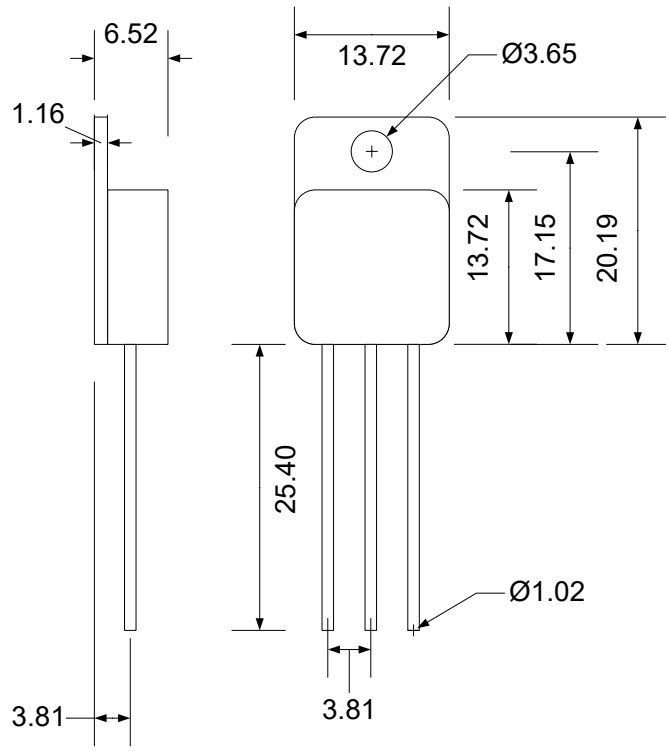

TO254 (mm +/- 10%)

Ordering Information

Ordering Reference	Package	Temperature Range	Marking	Status
CHT-NMOS8005-TO254-T	TO-254 metal can	-55°C to +225°C	CHT-NMOS8005	Not for new designs
CHT-NMOS8010-TO254-T	TO-254 metal can	-55°C to +225°C	CHT-NMOS8010	Active

Contact & Ordering

CISSOID S.A.

Headquarters and contact EMEA:	CISSOID S.A. – Rue Francqui, 3 – 1435 Mont Saint Guibert - Belgium T : +32 10 48 92 10 - F: +32 10 88 98 75 Email: sales@cissoid.com
Sales Representatives:	Visit our website: http://www.cissoid.com

Disclaimer

Neither CISSOID, nor any of its directors, employees or affiliates make any representations or extend any warranties of any kind, either express or implied, including but not limited to warranties of merchantability, fitness for a particular purpose, and the absence of latent or other defects, whether or not discoverable. In no event shall CISSOID, its directors, employees and affiliates be liable for direct, indirect, special, incidental or consequential damages of any kind arising out of the use of its circuits and their documentation, even if they have been advised of the possibility of such a damage. The circuits are provided "as is". CISSOID has no obligation to provide maintenance, support, updates, or modifications.