

LRMAP4026

Features

- 4-terminal Kelvin gullwing terminations
- Resistance range 0.2mΩ to 3mΩ
- 5W rating in compact footprint
- Robust welded construction
- Low inductance
- AEC-Q200 qualified



 All parts are Pb-free and comply with EU Directive 2011/65/EU amended by (EU) 2015/863 (RoHS3)

Electrical Data

		LRMAP4026						
Resistance value	mΩ	0.2	0.3	0.5	0.7	1.0	2.0	3.0
Power rating, P _{r100}	W	5	5	5	5	5	5	4
Alloy		B				C		
Internal thermal impedance, R _{thi}	°C/W	4	5	7	9	13	16	20
TCR (resistive alloy)	ppm/°C	-40 to 0						
TCR (resistor)	ppm/°C	±75					±50	
Resistance tolerance	%	±1						
Inductance	nH	< 3						
Ambient temperature range	°C	-65 to +170						

Physical Data

Dimensions in mm and weight in g								
Value	M ±0.4	W ±0.3	H ±0.5	X ±0.4	D nom.	A ±0.2	T nom.	Wt. nom.
L20	6.6	6.9	3.0	4.8	0.9	2.5	1.05	0.75
L30							1.06	0.87
L50							0.67	0.49
L70							0.48	0.36
1L0							0.33	0.28
2L0							0.47	0.38
3L0							0.34	0.24

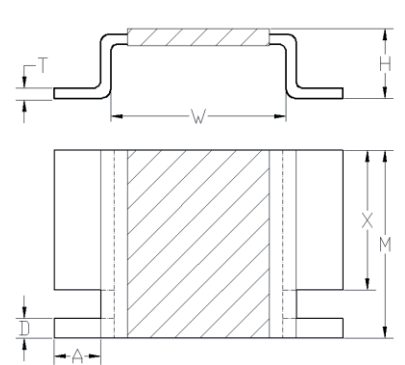

Mounting Pad Dimensions (mm)

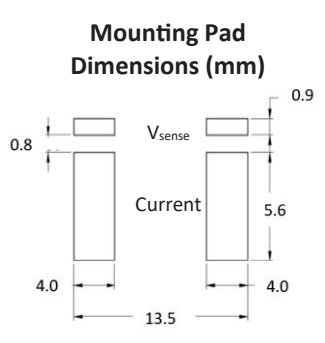

Marking

The component is laser marked with ohmic value (using R to indicate decimal position in ohms) and tolerance.

Solvent Resistance

The component is resistant to all normal industrial cleaning solvents suitable for printed circuits.

Construction

The component is formed from a continuous band of E-beam welded precision resistive strip. Different resistance alloys are used based on the resistance value. The component is supplied without plating.

General Note

TT Electronics reserves the right to make changes in product specification without notice or liability. All information is subject to TT Electronics' own data and is considered accurate at time of going to print.

LRMAP4026

Performance Data

Test	Methods	Reference	ΔR
Load Life	1000 hours, cyclic load at $T_A = 125^\circ\text{C}$, rated power per Temperature Derating graph below	MIL-STD-202 Method 108	$\pm 0.5\%$
Short Term Over-load	$5 \times P_{r100}$ for 5 s	MIL-STD-202 Method 201	$\pm 0.5\%$
High Temperature Exposure	1000 hours, $T_A = 125^\circ\text{C}$, unpowered	MIL-STD-202 Method 108	$\pm 0.5\%$
Temperature Cycle	1000 cycles, -55°C to $+125^\circ\text{C}$	JESD22 Method JA-104	$\pm 0.5\%$
Biased Humidity	1000 hours, $85^\circ\text{C}/85\%\text{RH}$, 10% of P_{r100}	MIL-STD-202 Method 103	$\pm 0.5\%$
Vibration	10 – 2000Hz, 5g, 20min, 12 cycles/axis x 3 axes	MIL-STD-202 Method 204	$\pm 0.5\%$
Resistance to Solder Heat	$260 \pm 5^\circ\text{C}$, $10 \pm 1\text{s}$	MIL-STD-202 Method 210	$\pm 0.5\%$
Solderability	$235 \pm 5^\circ\text{C}$, $2 \pm 0.5\text{s}$	J-STD-002	$\geq 95\%$ coverage

Temperature Derating
(0.5% Stability)

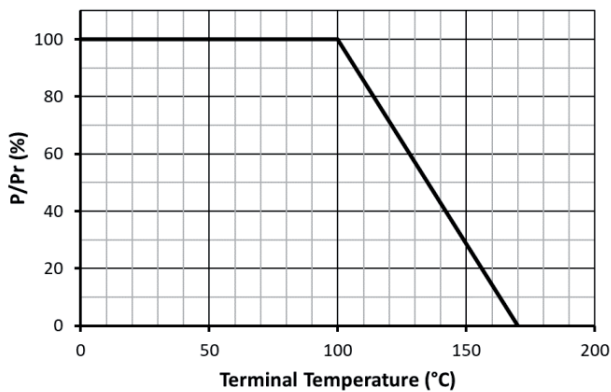

Typical Temperature Characteristic

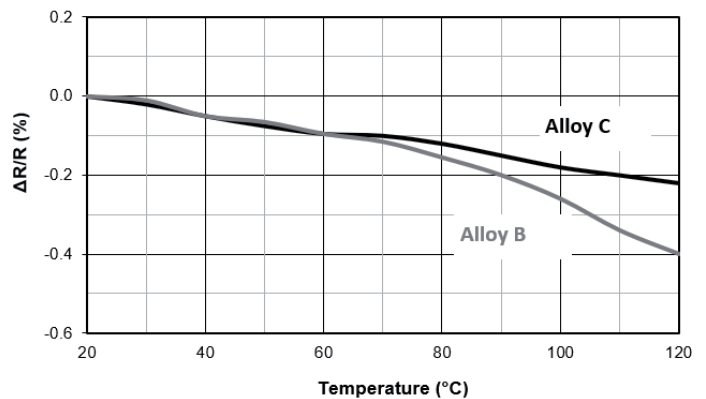

Packaging

All dimensions in mm

Size	A	B	W	E	F	P0	P1	P2	D0	T	Reel dia.
4026	7.5	12.1	24	1.75	12.2	6	12	12	1.5	3.5	330

General Note

TT Electronics reserves the right to make changes in product specification without notice or liability. All information is subject to TT Electronics' own data and is considered accurate at time of going to print.

LRMAP4026

Ordering Procedure

Example: LRMAP4026B-1L0FT1 (1 milliohm $\pm 1\%$, Pb-free)



1 Type	2 Alloy	3 Value	4 Tolerance	5 Packing
LRMAP4026	B	3 characters	F = $\pm 1\%$	T1 = plastic tape, 1000/reel
	C	L = milliohms		

General Note
 TT Electronics reserves the right to make changes in product specification without notice or liability.
 All information is subject to TT Electronics' own data and is considered accurate at time of going to print.