



flowPIM 1

1200 V / 50 A

Topology features

- Kelvin Emitter for improved switching performance
- Open Emitter configuration
- Temperature sensor
- Converter+Brake+Inverter

Component features

- Easy paralleling
- Low turn-off losses
- Low collector emitter saturation voltage
- Positive temperature coefficient
- Short tail current
- Switching optimized for EMC

Housing features

- Base isolation: Al₂O₃
- Convex shaped substrate for superior thermal contact
- Thermo-mechanical push-and-pull force relief
- Solder pin

Target applications

- Industrial Drives

Types

- 10-FY12PMA050M7-P580A78

flow 1 12 mm housing

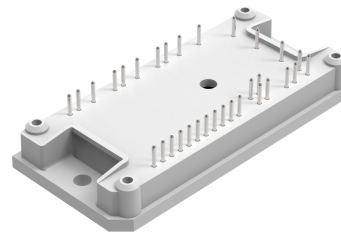

Schematic

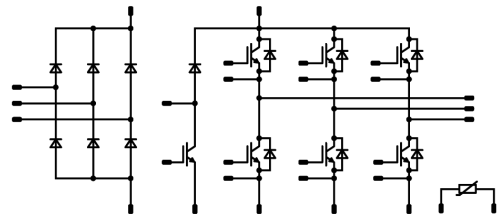



Vincotech

10-FY12PMA050M7-P580A78
datasheet

Maximum Ratings

$T_j = 25\text{ °C}$, unless otherwise specified

Parameter	Symbol	Conditions	Value	Unit
Inverter Switch				
Collector-emitter voltage	V_{CES}		1200	V
Collector current (DC current)	I_C	$T_j = T_{jmax}$ $T_s = 80\text{ °C}$	57	A
Repetitive peak collector current	I_{CRM}	t_p limited by T_{jmax}	100	A
Total power dissipation	P_{tot}	$T_j = T_{jmax}$ $T_s = 80\text{ °C}$	115	W
Gate-emitter voltage	V_{GES}		± 20	V
Short circuit ratings	t_{SC}	$V_{GE} = 15\text{ V}$, $V_{CC} = 800\text{ V}$ $T_j = 150\text{ °C}$	9,5	μs
Maximum junction temperature	T_{jmax}		175	$^{\circ}\text{C}$

Inverter Diode				
Peak repetitive reverse voltage	V_{RRM}		1200	V
Forward current (DC current)	I_F	$T_j = T_{jmax}$ $T_s = 80\text{ °C}$	45	A
Repetitive peak forward current	I_{FRM}	t_p limited by T_{jmax}	100	A
Total power dissipation	P_{tot}	$T_j = T_{jmax}$ $T_s = 80\text{ °C}$	78	W
Maximum junction temperature	T_{jmax}		175	$^{\circ}\text{C}$

Brake Switch				
Collector-emitter voltage	V_{CES}		1200	V
Collector current (DC current)	I_C	$T_j = T_{jmax}$ $T_s = 80\text{ °C}$	51	A
Repetitive peak collector current	I_{CRM}	t_p limited by T_{jmax}	70	A
Total power dissipation	P_{tot}	$T_j = T_{jmax}$ $T_s = 80\text{ °C}$	107	W
Gate-emitter voltage	V_{GES}		± 20	V
Short circuit ratings	t_{SC}	$V_{GE} = 15\text{ V}$, $V_{CC} = 800\text{ V}$ $T_j = 150\text{ °C}$	9,5	μs
Maximum junction temperature	T_{jmax}		175	$^{\circ}\text{C}$



Vincotech

Maximum Ratings

$T_j = 25\text{ °C}$, unless otherwise specified

Parameter	Symbol	Conditions	Value	Unit
Brake Diode				
Peak repetitive reverse voltage	V_{RRM}		1200	V
Forward current (DC current)	I_F	$T_j = T_{jmax}$ $T_s = 80\text{ °C}$	33	A
Repetitive peak forward current	I_{FRM}	t_p limited by T_{jmax}	50	A
Total power dissipation	P_{tot}	$T_j = T_{jmax}$ $T_s = 80\text{ °C}$	62	W
Maximum junction temperature	T_{jmax}		175	°C

Rectifier Diode

Peak repetitive reverse voltage	V_{RRM}		1600	V
Forward current (DC current)	I_F	$T_j = T_{jmax}$ $T_s = 80\text{ °C}$	54	A
Surge (non-repetitive) forward current	I_{FSM}	Single Half Sine Wave, $t_p = 10\text{ ms}$ $T_j = 150\text{ °C}$	350	A
Surge current capability	I^2t		610	A ² s
Total power dissipation	P_{tot}	$T_j = T_{jmax}$ $T_s = 80\text{ °C}$	65	W
Maximum junction temperature	T_{jmax}		150	°C

Module Properties

Thermal Properties

Storage temperature	T_{stg}		-40...+125	°C
Operation temperature under switching condition	T_{jop}		-40...+($T_{jmax} - 25$)	°C

Isolation Properties

Isolation voltage	V_{isol}	DC Test Voltage* $t_p = 2\text{ s}$	6000	V
Isolation voltage	V_{isol}	AC Voltage $t_p = 1\text{ min}$	2500	V
Creepage distance			>12,7	mm
Clearance			7,91	mm
Comparative Tracking Index	CTI		≥ 200	

*100 % tested in production



Vincotech

Characteristic Values

Parameter	Symbol	Conditions					Values			Unit
		V_{GS} [V]	V_{GE} [V]	V_{DS} [V]	V_F [V]	I_C [A] I_D [A] I_F [A]	T_j [°C]	Min	Typ	

Inverter Switch

Static

Gate-emitter threshold voltage	$V_{GE(th)}$			10	0,005	25	5,4	6	6,6	V
Collector-emitter saturation voltage	$V_{CE(sat)}$		15		50	25 125 150		1,55 1,77 1,83	1,9 ⁽¹⁾	V
Collector-emitter cut-off current	I_{CES}		0	1200		25			0,09	mA
Gate-emitter leakage current	I_{GES}		20	0		25			0,5	μA
Internal gate resistance	r_g							None		Ω
Input capacitance	C_{ies}							10000		pF
Output capacitance	C_{oes}		0	10		25		350		pF
Reverse transfer capacitance	C_{res}							130		pF
Gate charge	Q_g	$V_{CC} = 600$ V	0/15		50	25		380		nC

Thermal

Thermal resistance junction to sink ⁽²⁾	$R_{th(j-s)}$	$\lambda_{paste} = 3,4$ W/mK (PSX)						0,82		K/W
--	---------------	---------------------------------------	--	--	--	--	--	------	--	-----

Dynamic

Turn-on delay time	$t_{d(on)}$					25 125 150		176 176 190		ns
Rise time	t_r					25 125 150		52 58 60		ns
Turn-off delay time	$t_{d(off)}$					25 125 150		206 229 241		ns
Fall time	t_f					25 125 150		92,14 124,72 122,14		ns
Turn-on energy (per pulse)	E_{on}	$Q_{tFWD} = 4,93$ μC $Q_{tFWD} = 7,08$ μC $Q_{tFWD} = 8,04$ μC				25 125 150		4,82 6,38 6,25		mWs
Turn-off energy (per pulse)	E_{off}					25 125 150		2,98 4,25 5,03		mWs



Vincotech

Characteristic Values

Parameter	Symbol	Conditions					Values			Unit
		V_{GE} [V] V_{GS} [V]	V_{CE} [V] V_{DS} [V] V_F [V]	I_C [A] I_D [A] I_F [A]	T_j [°C]	Min	Typ	Max		
Inverter Diode										
Static										
Forward voltage	V_F			50	25 125 150		1,66 1,78 1,79	2,1 ⁽¹⁾		V
Reverse leakage current	I_R	$V_r = 1200$ V			25			40		μA
Thermal										
Thermal resistance junction to sink ⁽²⁾	$R_{th(j-s)}$	$\lambda_{paste} = 3,4$ W/mK (PSX)					1,22			K/W
Dynamic										
Peak recovery current	I_{RM}				25 125 150		28,72 32,83 32,97			A
Reverse recovery time	t_{rr}				25 125 150		339,05 434,87 511,31			ns
Recovered charge	Q_r	$di/dt=338$ A/μs $di/dt=450$ A/μs $di/dt=498$ A/μs	±15	600	50	25 125 150	4,93 7,08 8,04			μC
Reverse recovered energy	E_{rec}				25 125 150		1,79 2,59 3,33			mWs
Peak rate of fall of recovery current	$(di_r/dt)_{max}$				25 125 150		194,94 128,35 114,47			A/μs



Characteristic Values

Parameter	Symbol	Conditions					Values			Unit
		V_{GE} [V] V_{GS} [V]	V_{CE} [V] V_{DS} [V] V_F [V]	I_C [A] I_D [A] I_F [A]	T_j [°C]	Min	Typ	Max		

Brake Switch

Static

Gate-emitter threshold voltage	$V_{GE(th)}$			10	0,0035	25	5,4	6	6,6	V
Collector-emitter saturation voltage	$V_{CE(sat)}$		15		35	25 125 150		1,47 1,64 1,68	1,85 ⁽¹⁾	V
Collector-emitter cut-off current	I_{CES}		0	1200		25			80	μA
Gate-emitter leakage current	I_{GES}		20	0		25			200	nA
Internal gate resistance	r_g							None		Ω
Input capacitance	C_{ies}							7900		pF
Output capacitance	C_{oes}		0	10		25		270		pF
Reverse transfer capacitance	C_{res}							97		pF
Gate charge	Q_g	$V_{CC} = 600$ V	0/15		35	25		260		nC

Thermal

Thermal resistance junction to sink ⁽²⁾	$R_{th(j-s)}$	$\lambda_{paste} = 3,4$ W/mK (PSX)						0,89		K/W
--	---------------	---------------------------------------	--	--	--	--	--	------	--	-----

Dynamic

Turn-on delay time	$t_{d(on)}$					25 125 150		199,4 172,4 167		ns
Rise time	t_r					25 125 150		111,2 109,2 110,4		ns
Turn-off delay time	$t_{d(off)}$					25 125 150		437,6 485,4 497,2		ns
Fall time	t_f					25 125 150		64,65 99,99 107,31		ns
Turn-on energy (per pulse)	E_{on}	$Q_{tFWD}=2,81$ μC $Q_{tFWD}=4,53$ μC $Q_{tFWD}=5,09$ μC				25 125 150		4,87 5,85 6,1		mWs
Turn-off energy (per pulse)	E_{off}					25 125 150		3 3,88 4,1		mWs



Vincotech

10-FY12PMA050M7-P580A78
datasheet

Characteristic Values

Parameter	Symbol	Conditions					Values			Unit
		V_{GE} [V] V_{GS} [V]	V_{CE} [V] V_{DS} [V] V_F [V]	I_C [A] I_D [A] I_F [A]	T_j [°C]	Min	Typ	Max		
Brake Diode										
Static										
Forward voltage	V_F				25	25 125 150		1,63 1,7 1,69	2,1 ⁽¹⁾	V
Reverse leakage current	I_R	$V_T = 1200$ V				25			35	μA
Thermal										
Thermal resistance junction to sink ⁽²⁾	$R_{th(j-s)}$	$\lambda_{paste} = 3,4$ W/mK (PSX)						1,54		K/W
Dynamic										
Peak recovery current	I_{RM}					25 125 150		17,92 19,64 20,47		A
Reverse recovery time	t_{rr}					25 125 150		269,22 397,4 448,88		ns
Recovered charge	Q_r	$di/dt=310$ A/μs $di/dt=311$ A/μs $di/dt=260$ A/μs	0/15	700	35	25 125 150		2,81 4,53 5,09		μC
Reverse recovered energy	E_{rec}					25 125 150		1,12 1,92 2,21		mWs
Peak rate of fall of recovery current	$(di_r/dt)_{max}$					25 125 150		132,1 79,89 77,49		A/μs



Characteristic Values

Parameter	Symbol	Conditions					Values			Unit
		V_{GE} [V] V_{GS} [V]	V_{CE} [V] V_{DS} [V] V_F [V]	I_C [A] I_D [A] I_F [A]	T_j [°C]	Min	Typ	Max		

Rectifier Diode

Static

Forward voltage	V_F				18	25 125 150		0,99 0,912 0,908	1,21 ⁽¹⁾ 1,1 ⁽¹⁾	V
Reverse leakage current	I_R	$V_T = 1600$ V				25			50	μA

Thermal

Thermal resistance junction to sink ⁽²⁾	$R_{th(j-s)}$	$\lambda_{paste} = 3,4$ W/mK (PSX)						1,08		K/W
--	---------------	---------------------------------------	--	--	--	--	--	------	--	-----

Thermistor

Static

Rated resistance	R					25		22		kΩ
Deviation of R_{100}	$\Delta_{R/R}$	$R_{100} = 1484$ Ω				100	-5		5	%
Power dissipation	P					25		130		mW
Power dissipation constant	d					25		1,5		mW/K
B-value	$B_{(25/50)}$	Tol. ±1 %						3962		K
B-value	$B_{(25/100)}$	Tol. ±1 %						4000		K
Vincotech Thermistor Reference									I	

⁽¹⁾ Value at chip level

⁽²⁾ Only valid with pre-applied Vincotech thermal interface material.



Inverter Switch Characteristics

figure 1. IGBT

Typical output characteristics
 $I_C = f(V_{CE})$

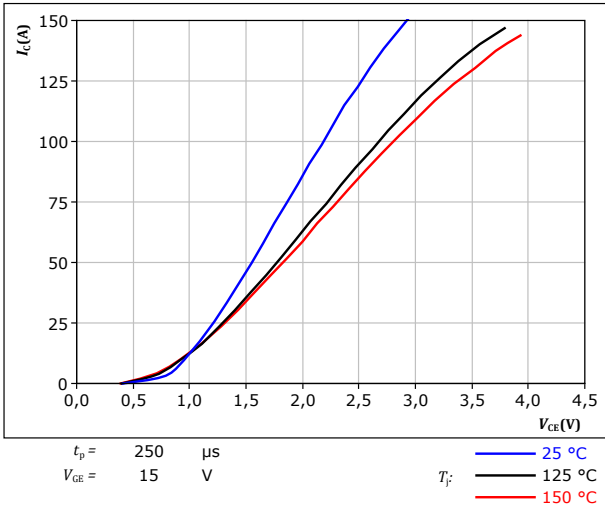

figure 2. IGBT

Typical output characteristics
 $I_C = f(V_{CE})$

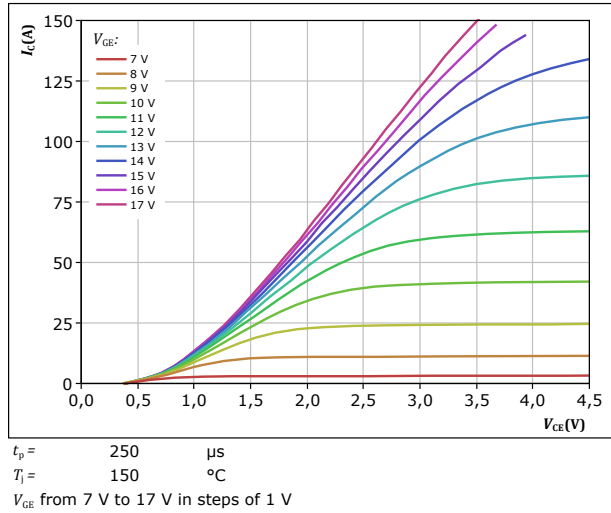

figure 3. IGBT

Typical transfer characteristics
 $I_C = f(V_{GE})$

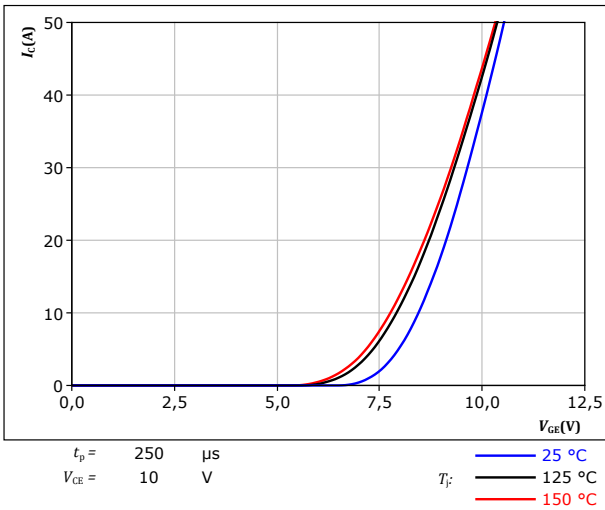
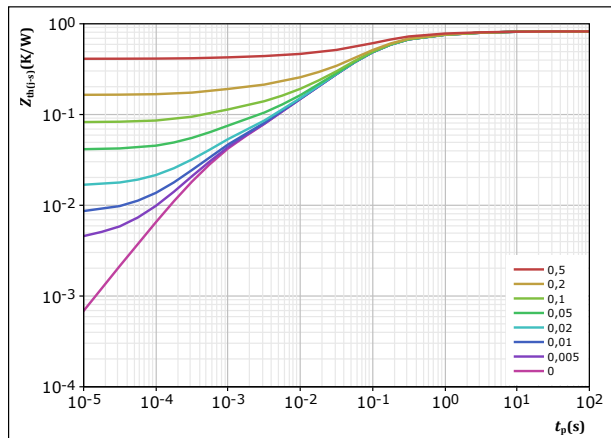

figure 4. IGBT

Transient thermal impedance as a function of pulse width
 $Z_{th(j-s)} = f(t_p)$



$D = t_p / T$
 $R_{th(j-s)} = 0,823 \text{ K/W}$

IGBT thermal model values

R (K/W)	τ (s)
4,05E-02	5,17E+00
8,54E-02	1,03E+00
3,18E-01	1,67E-01
2,80E-01	5,49E-02
6,47E-02	7,32E-03
3,43E-02	6,46E-04



Inverter Switch Characteristics

figure 5. IGBT

Safe operating area
 $I_C = f(V_{CE})$

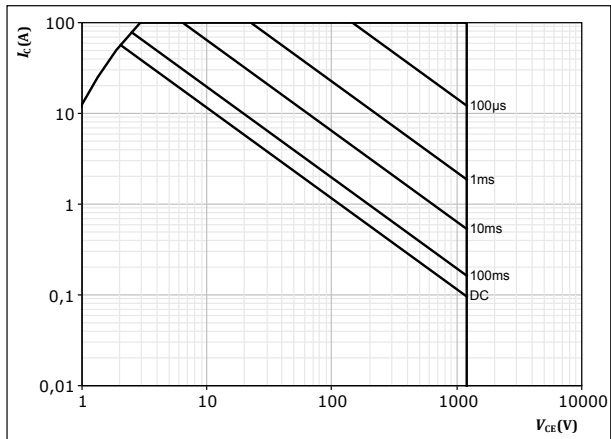

$D =$ single pulse
 $T_s = 80$ °C
 $V_{GE} = 15$ V
 $T_j = T_{jmax}$

figure 6. IGBT

Gate voltage vs gate charge
 $V_{GE} = f(Q_g)$

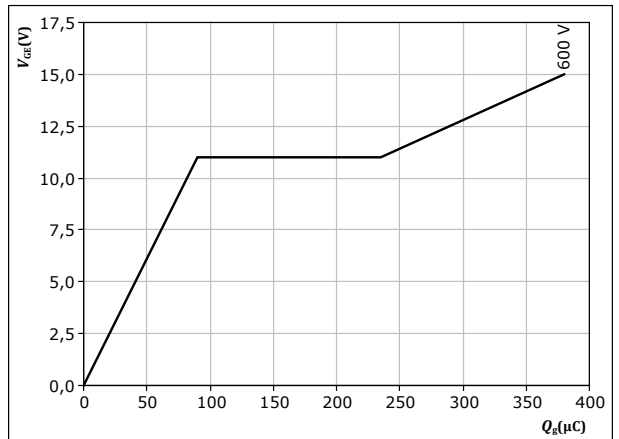

$I_C = 50$ A
 $T_j = 25$ °C



Inverter Diode Characteristics

figure 7. FWD

Typical forward characteristics

$$I_F = f(V_F)$$

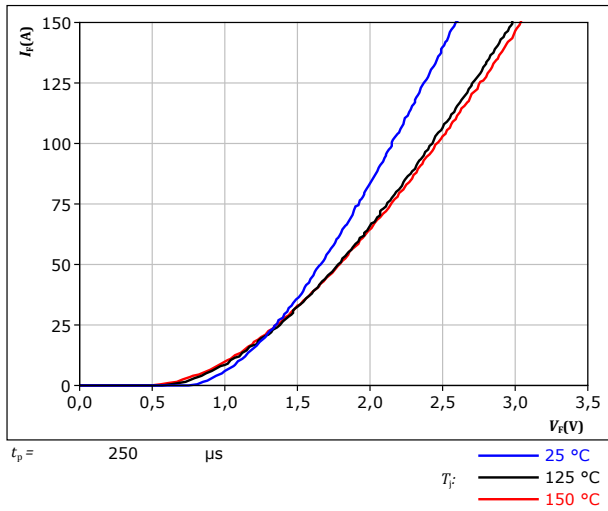
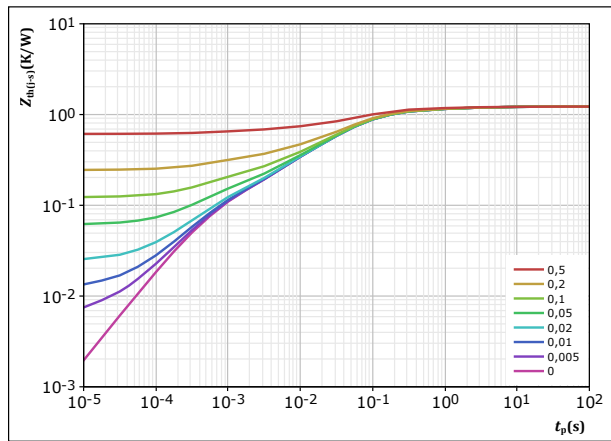

figure 8. FWD

Transient thermal impedance as a function of pulse width

$$Z_{th(j-s)} = f(t_p)$$



$D = t_p / T$
 $R_{th(j-s)} = 1,224 \text{ K/W}$
 FWD thermal model values

R (K/W)	τ (s)
3,84E-02	6,82E+00
9,89E-02	9,92E-01
3,93E-01	1,28E-01
4,67E-01	3,75E-02
1,41E-01	5,65E-03
8,52E-02	5,44E-04



Brake Switch Characteristics

figure 9. IGBT

Typical output characteristics

$$I_C = f(V_{CE})$$

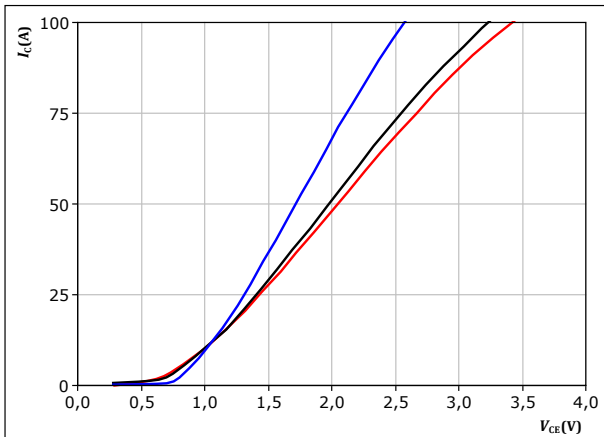

$t_p = 250 \mu s$
 $V_{GE} = 15 V$
 $T_j:$ — 25 °C
— 125 °C
— 150 °C

figure 10. IGBT

Typical output characteristics

$$I_C = f(V_{CE})$$

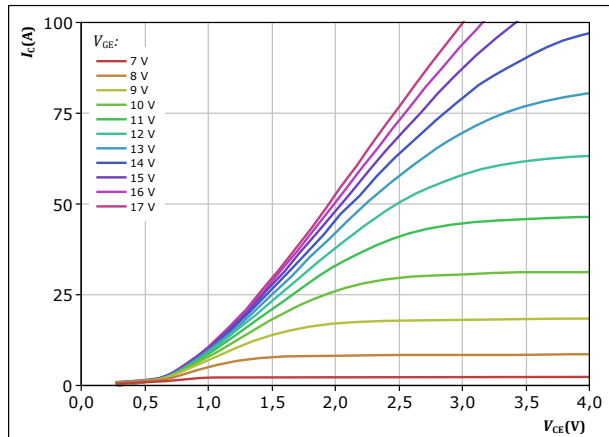

$t_p = 250 \mu s$
 $T_j = 150 \text{ °C}$
 V_{GE} from 7 V to 17 V in steps of 1 V

figure 11. IGBT

Typical transfer characteristics

$$I_C = f(V_{GE})$$

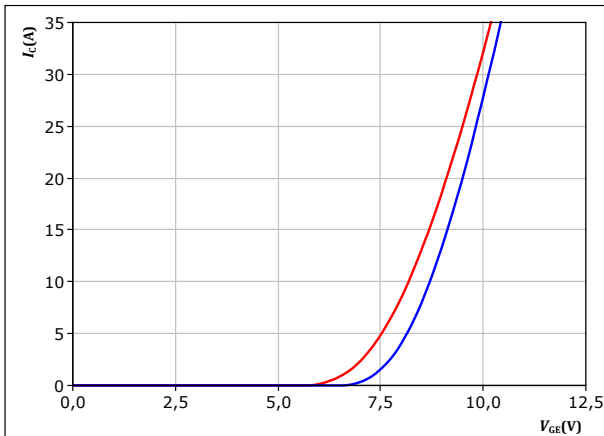

$t_p = 250 \mu s$
 $V_{CE} = 10 V$
 $T_j:$ — 25 °C
— 125 °C

figure 12. IGBT

Transient thermal impedance as a function of pulse width

$$Z_{th(j-s)} = f(t_p)$$

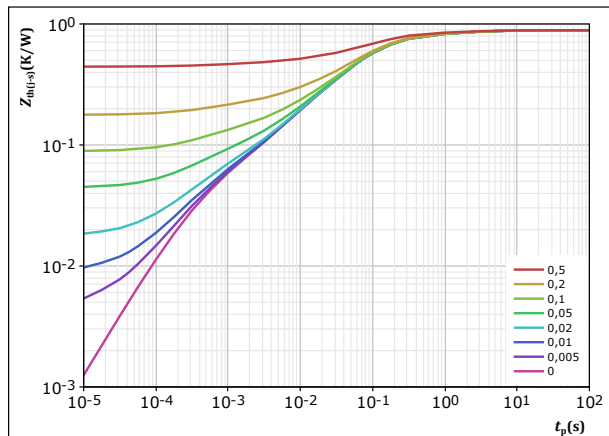

$D = t_p / T$
 $R_{th(j-s)} = 0,888 \text{ K/W}$

IGBT thermal model values

R (K/W)	τ (s)
4,56E-02	3,89E+00
8,84E-02	7,65E-01
3,30E-01	1,35E-01
2,86E-01	4,71E-02
8,94E-02	7,49E-03
3,24E-02	8,15E-04
1,67E-02	2,52E-04



Brake Switch Characteristics

figure 13. IGBT

Safe operating area
 $I_C = f(V_{CE})$

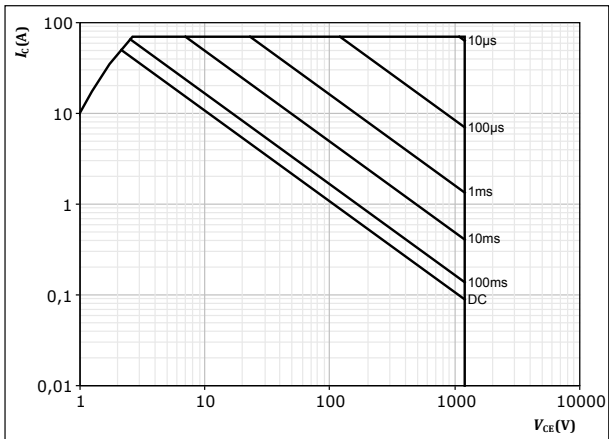

$D =$ single pulse
 $T_s = 80 \text{ } ^\circ\text{C}$
 $V_{GE} = 15 \text{ V}$
 $T_j = T_{jmax}$

figure 14. IGBT

Gate voltage vs gate charge
 $V_{GE} = f(Q_g)$

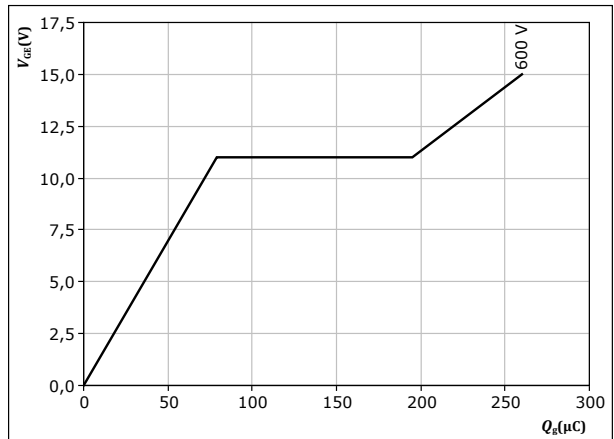

$I_C = 35 \text{ A}$
 $T_j = 25 \text{ } ^\circ\text{C}$



Brake Diode Characteristics

figure 15. FWD

Typical forward characteristics

$$I_F = f(V_F)$$

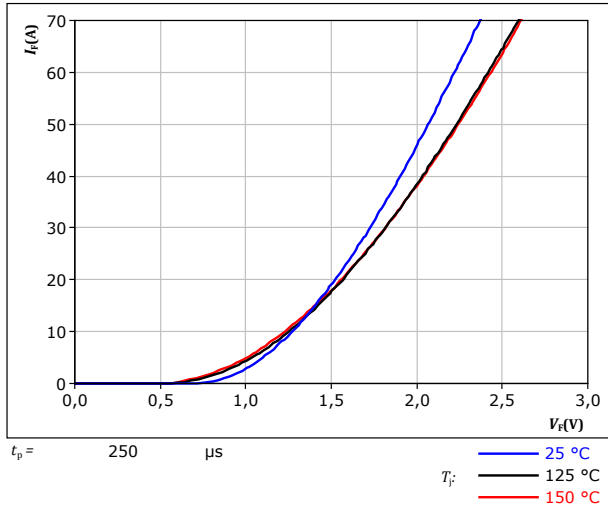
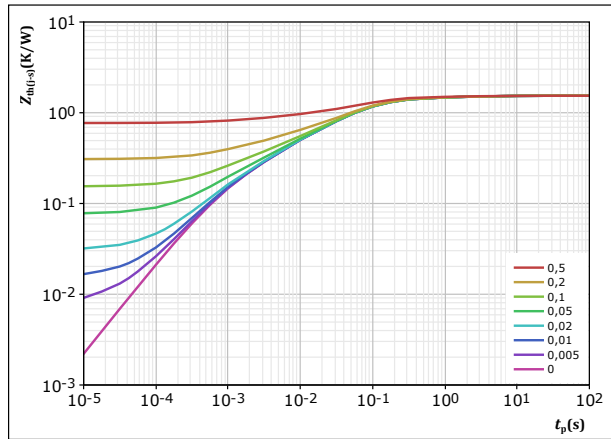

figure 16. FWD

Transient thermal impedance as a function of pulse width

$$Z_{th(j-s)} = f(t_p)$$



$D = t_p / T$

$R_{th(j-s)} = 1,539 \text{ K/W}$

FWD thermal model values

R (K/W)	τ (s)
4,69E-02	5,05E+00
1,06E-01	7,09E-01
5,57E-01	1,01E-01
4,68E-01	3,22E-02
2,35E-01	5,52E-03
8,77E-02	1,01E-03
4,01E-02	5,52E-04



Rectifier Diode Characteristics

figure 17. Rectifier

Typical forward characteristics

$$I_F = f(V_F)$$

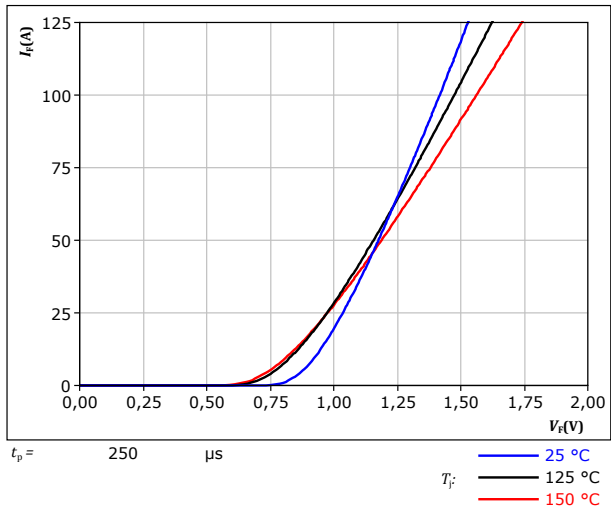
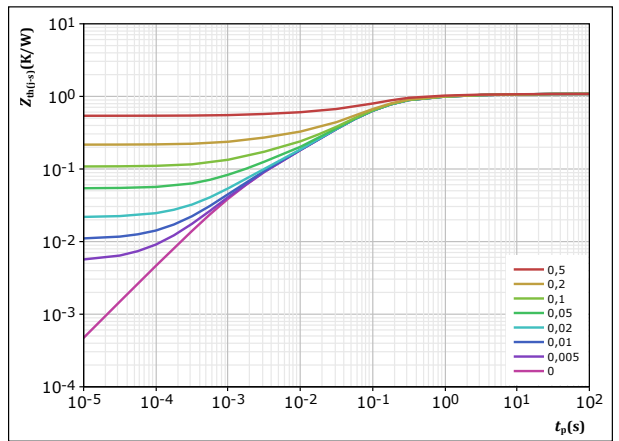

figure 18. Rectifier

Transient thermal impedance as a function of pulse width

$$Z_{th(j-s)} = f(t_p)$$



$D = t_p / T$
 $R_{th(j-s)} = 1,082$ K/W
 Rectifier thermal model values

R (K/W)	τ (s)
4,60E-02	9,93E+00
1,23E-01	1,00E+00
4,58E-01	1,51E-01
3,31E-01	5,61E-02
7,76E-02	9,34E-03
4,64E-02	1,55E-03



Thermistor Characteristics

figure 19. Thermistor

Typical NTC characteristic as function of temperature

$$R_T = f(T)$$

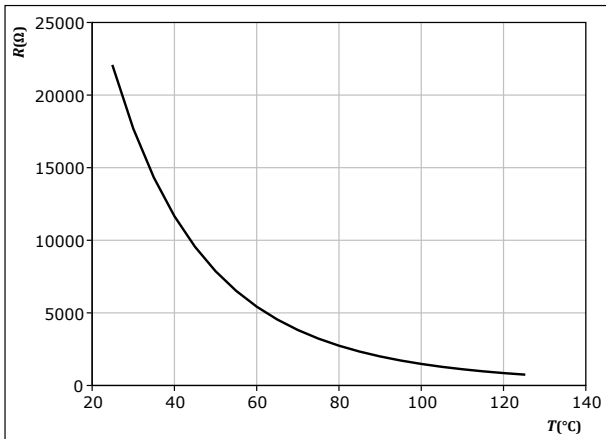



Inverter Switching Characteristics

figure 20. IGBT

Typical switching energy losses as a function of collector current
 $E = f(I_c)$

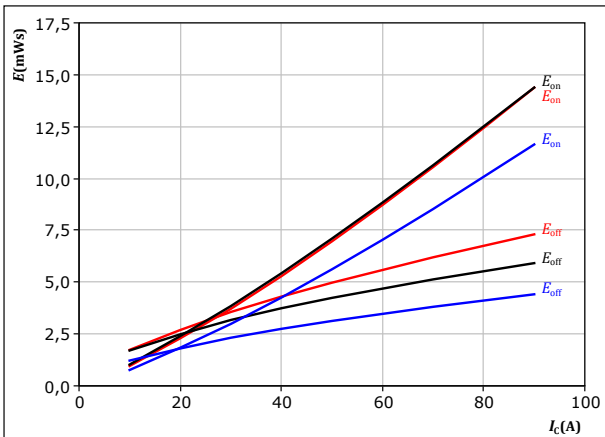

With an inductive load at

$V_{CE} =$	600	V	$T_j:$	—	25 °C
$V_{GE} =$	±15	V		—	125 °C
$R_{g(on)} =$	8	Ω		—	150 °C
$R_{g(off)} =$	8	Ω			

figure 21. IGBT

Typical switching energy losses as a function of IGBT turn on gate resistor
 $E = f(R_g)$

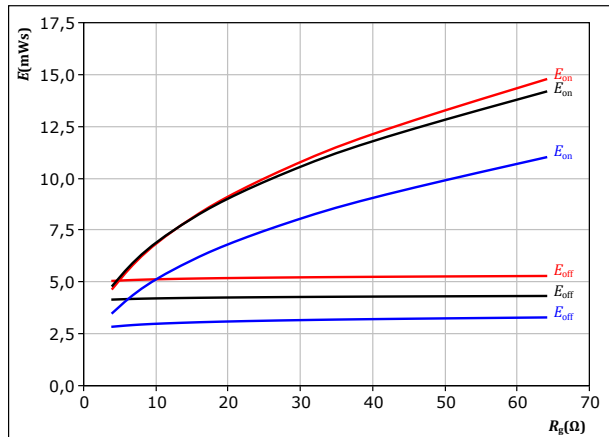

With an inductive load at

$V_{CE} =$	600	V	$T_j:$	—	25 °C
$V_{GE} =$	±15	V		—	125 °C
$I_c =$	50	A		—	150 °C

figure 22. FWD

Typical reverse recovered energy loss as a function of collector current
 $E_{rec} = f(I_c)$

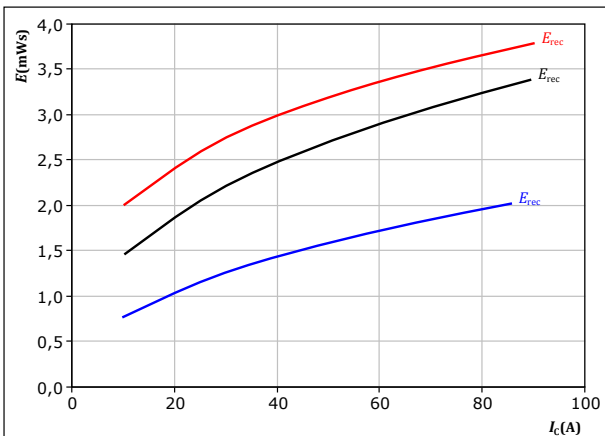

With an inductive load at

$V_{CE} =$	600	V	$T_j:$	—	25 °C
$V_{GE} =$	±15	V		—	125 °C
$R_{g(on)} =$	8	Ω		—	150 °C

figure 23. FWD

Typical reverse recovered energy loss as a function of IGBT turn on gate resistor
 $E_{rec} = f(R_g)$

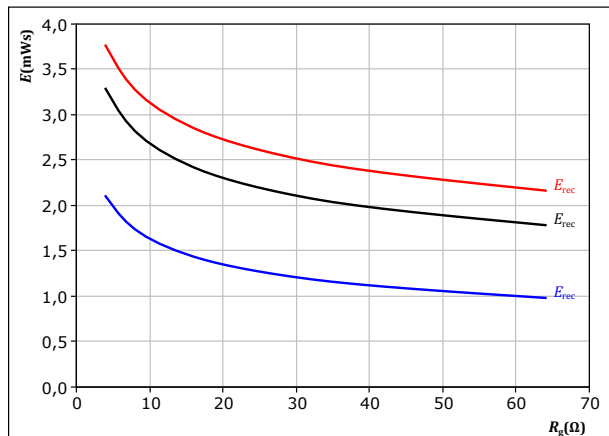

With an inductive load at

$V_{CE} =$	600	V	$T_j:$	—	25 °C
$V_{GE} =$	±15	V		—	125 °C
$I_c =$	50	A		—	150 °C



Inverter Switching Characteristics

figure 24. IGBT

Typical switching times as a function of collector current
 $t = f(I_c)$

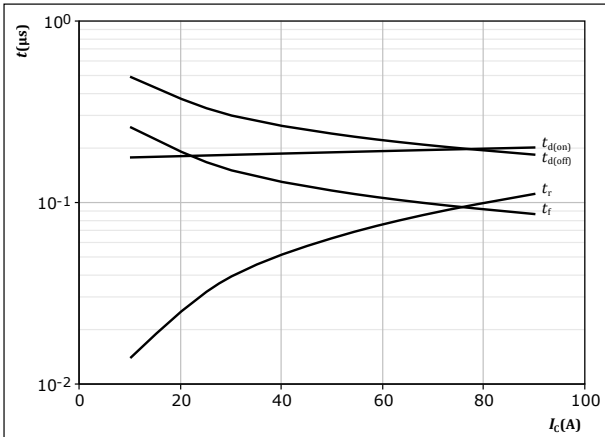

With an inductive load at
 $T_j = 150 \text{ }^\circ\text{C}$
 $V_{CE} = 600 \text{ V}$
 $V_{GE} = \pm 15 \text{ V}$
 $R_{gon} = 8 \text{ } \Omega$
 $R_{goff} = 8 \text{ } \Omega$

figure 25. IGBT

Typical switching times as a function of IGBT turn on gate resistor
 $t = f(R_g)$

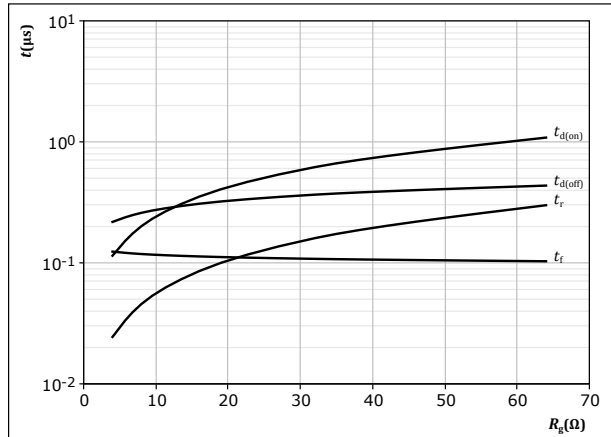

With an inductive load at
 $T_j = 150 \text{ }^\circ\text{C}$
 $V_{CE} = 600 \text{ V}$
 $V_{GE} = \pm 15 \text{ V}$
 $I_c = 50 \text{ A}$

figure 26. FWD

Typical reverse recovery time as a function of collector current
 $t_{rr} = f(I_c)$

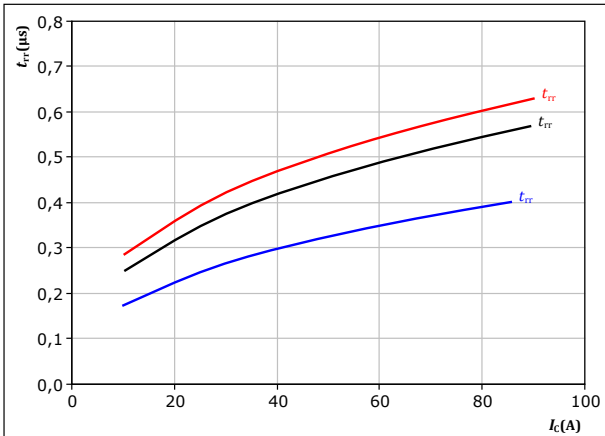

With an inductive load at
 $V_{CE} = 600 \text{ V}$
 $V_{GE} = \pm 15 \text{ V}$
 $R_{gon} = 8 \text{ } \Omega$
 $T_j:$ — 25 °C
— 125 °C
— 150 °C

figure 27. FWD

Typical reverse recovery time as a function of IGBT turn on gate resistor
 $t_{rr} = f(R_{gon})$

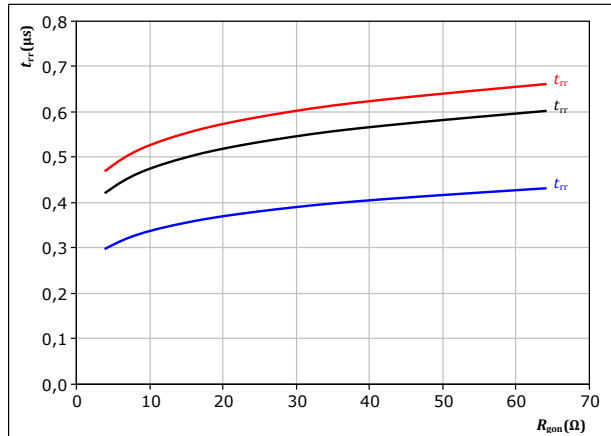

With an inductive load at
 $V_{CE} = 600 \text{ V}$
 $V_{GE} = \pm 15 \text{ V}$
 $I_c = 50 \text{ A}$
 $T_j:$ — 25 °C
— 125 °C
— 150 °C



Inverter Switching Characteristics

figure 28. FWD

Typical recovered charge as a function of collector current

$$Q_r = f(I_c)$$

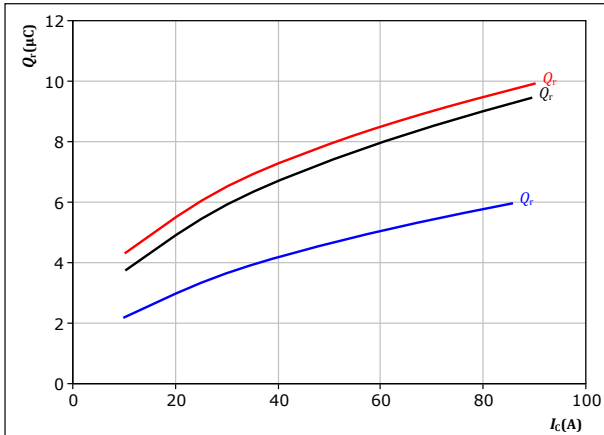

With an inductive load at

$V_{CE} = 600$ V
 $V_{GE} = \pm 15$ V
 $R_{gon} = 8$ Ω

T_j : — 25 °C
— 125 °C
— 150 °C

figure 29. FWD

Typical recovered charge as a function of IGBT turn on gate resistor

$$Q_r = f(R_{gon})$$

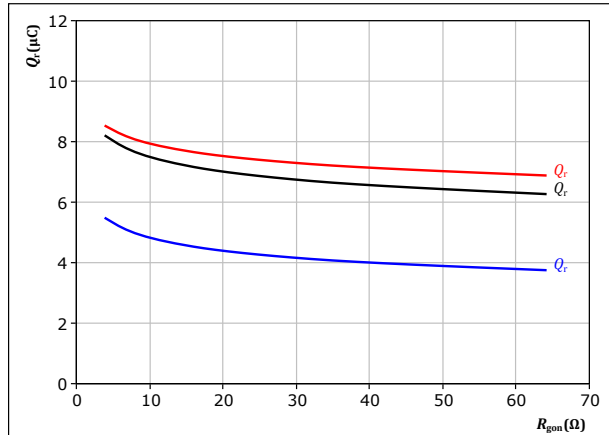

With an inductive load at

$V_{CE} = 600$ V
 $V_{GE} = \pm 15$ V
 $I_c = 50$ A

T_j : — 25 °C
— 125 °C
— 150 °C

figure 30. FWD

Typical peak reverse recovery current as a function of collector current

$$I_{RM} = f(I_c)$$

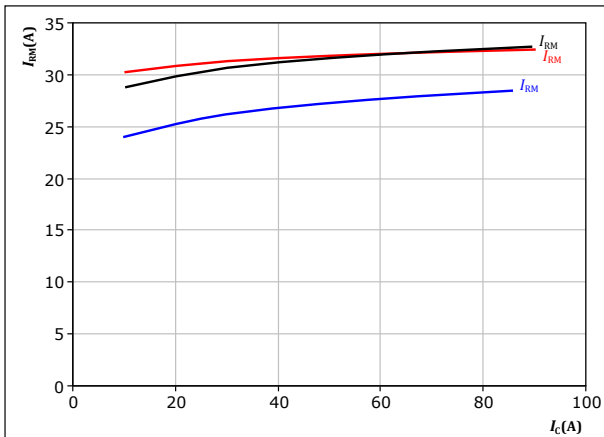

With an inductive load at

$V_{CE} = 600$ V
 $V_{GE} = \pm 15$ V
 $R_{gon} = 8$ Ω

T_j : — 25 °C
— 125 °C
— 150 °C

figure 31. FWD

Typical peak reverse recovery current as a function of IGBT turn on gate resistor

$$I_{RM} = f(R_{gon})$$

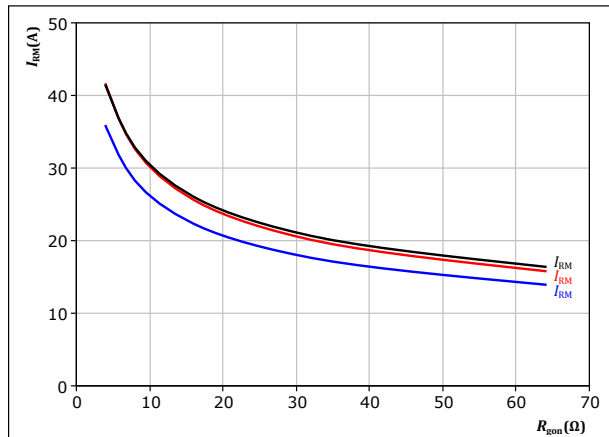

With an inductive load at

$V_{CE} = 600$ V
 $V_{GE} = \pm 15$ V
 $I_c = 50$ A

T_j : — 25 °C
— 125 °C
— 150 °C



Inverter Switching Characteristics

figure 32. FWD

Typical rate of fall of forward and reverse recovery current as a function of collector current
 $di_f/dt, di_r/dt = f(I_c)$

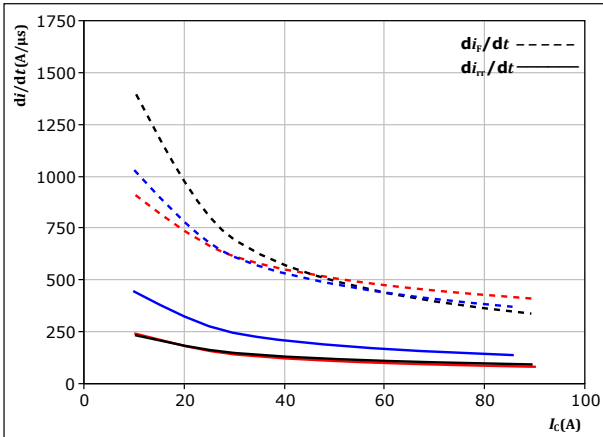

With an inductive load at

$V_{CE} = 600 \text{ V}$
 $V_{GE} = \pm 15 \text{ V}$
 $R_{gon} = 8 \ \Omega$

$T_j:$
— 25 °C
— 125 °C
— 150 °C

figure 33. FWD

Typical rate of fall of forward and reverse recovery current as a function of turn on gate resistor
 $di_f/dt, di_r/dt = f(R_{gon})$

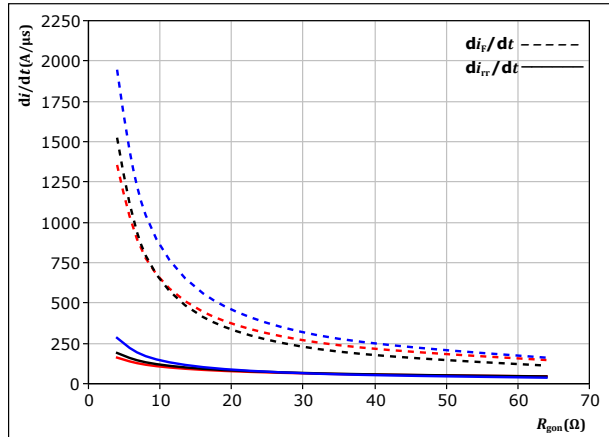

With an inductive load at

$V_{CE} = 600 \text{ V}$
 $V_{GE} = \pm 15 \text{ V}$
 $I_c = 50 \text{ A}$

$T_j:$
— 25 °C
— 125 °C
— 150 °C

figure 34. IGBT

Reverse bias safe operating area

$I_c = f(V_{CE})$

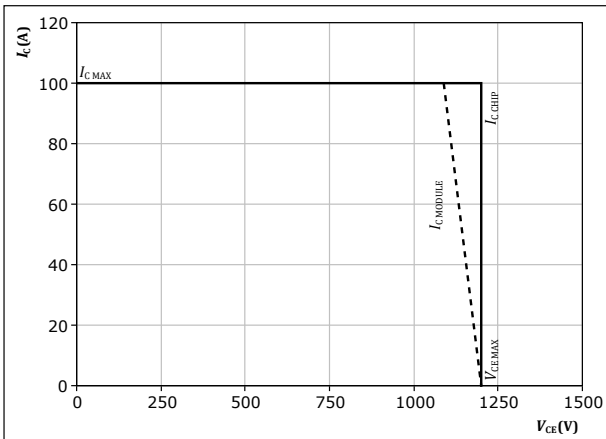

At $T_j = 150 \text{ °C}$
 $R_{gon} = 8 \ \Omega$
 $R_{goff} = 8 \ \Omega$



Brake Switching Characteristics

figure 35. IGBT

Typical switching energy losses as a function of collector current
 $E = f(I_c)$

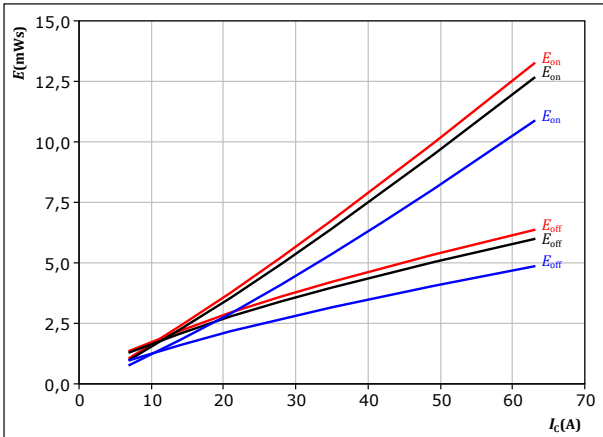

With an inductive load at
 $V_{CE} = 700 \text{ V}$
 $V_{GE} = 0/15 \text{ V}$
 $R_{gon} = 16 \ \Omega$
 $R_{goff} = 16 \ \Omega$
 T_j : 25 °C (blue), 125 °C (black), 150 °C (red)

figure 36. IGBT

Typical switching energy losses as a function of IGBT turn on gate resistor
 $E = f(R_g)$

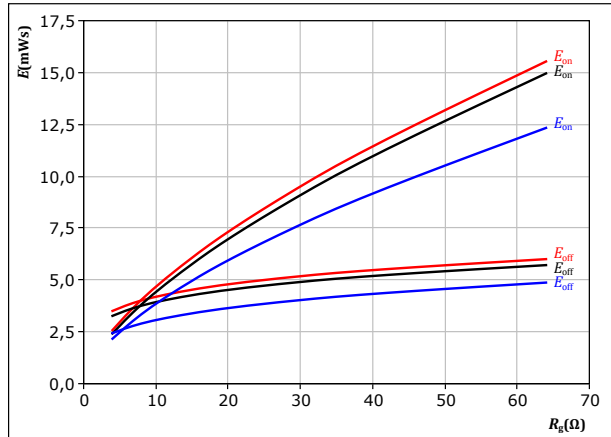

With an inductive load at
 $V_{CE} = 700 \text{ V}$
 $V_{GE} = 0/15 \text{ V}$
 $I_c = 35 \text{ A}$
 T_j : 25 °C (blue), 125 °C (black), 150 °C (red)

figure 37. FWD

Typical reverse recovered energy loss as a function of collector current
 $E_{rec} = f(I_c)$

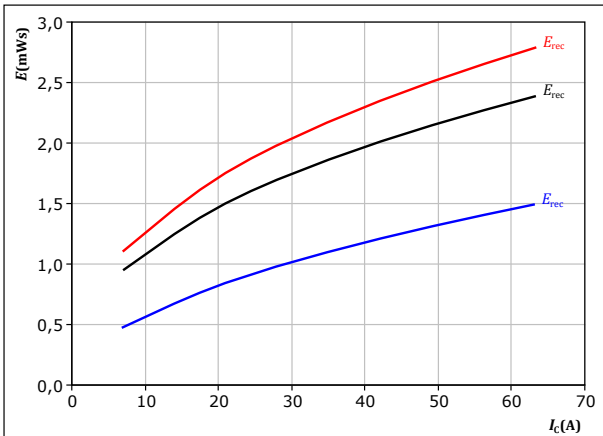

With an inductive load at
 $V_{CE} = 700 \text{ V}$
 $V_{GE} = 0/15 \text{ V}$
 $R_{gon} = 16 \ \Omega$
 T_j : 25 °C (blue), 125 °C (black), 150 °C (red)

figure 38. FWD

Typical reverse recovered energy loss as a function of IGBT turn on gate resistor
 $E_{rec} = f(R_g)$

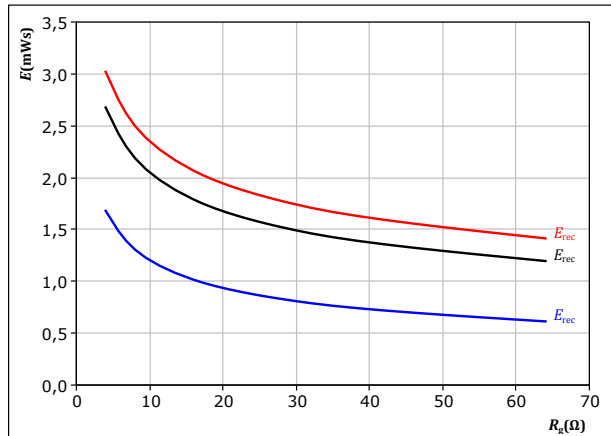

With an inductive load at
 $V_{CE} = 700 \text{ V}$
 $V_{GE} = 0/15 \text{ V}$
 $I_c = 35 \text{ A}$
 T_j : 25 °C (blue), 125 °C (black), 150 °C (red)



Brake Switching Characteristics

figure 39. IGBT

Typical switching times as a function of collector current
 $t = f(I_c)$

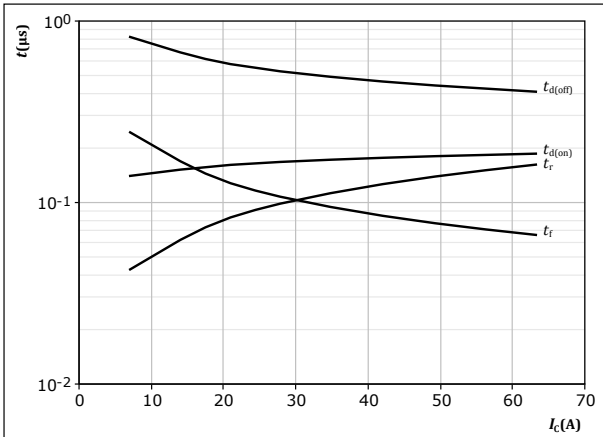

With an inductive load at
 $T_j = 150 \text{ }^\circ\text{C}$
 $V_{CE} = 700 \text{ V}$
 $V_{GE} = 0/15 \text{ V}$
 $R_{gon} = 16 \text{ } \Omega$
 $R_{goff} = 16 \text{ } \Omega$

figure 40. IGBT

Typical switching times as a function of IGBT turn on gate resistor
 $t = f(R_g)$

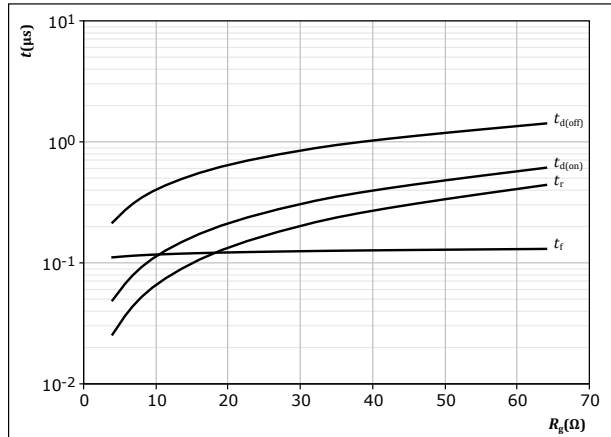

With an inductive load at
 $T_j = 150 \text{ }^\circ\text{C}$
 $V_{CE} = 700 \text{ V}$
 $V_{GE} = 0/15 \text{ V}$
 $I_c = 35 \text{ A}$

figure 41. FWD

Typical reverse recovery time as a function of collector current
 $t_{rr} = f(I_c)$

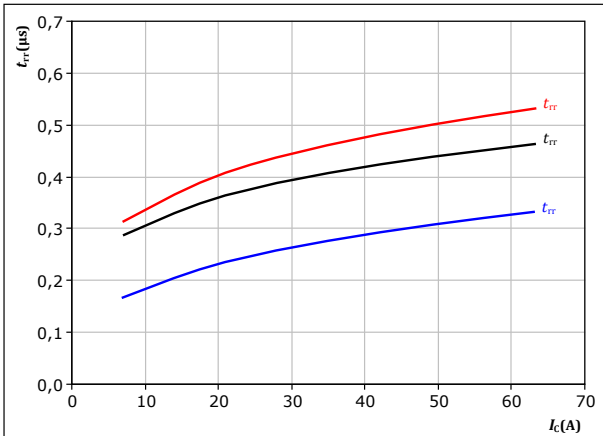

With an inductive load at
 $V_{CE} = 700 \text{ V}$
 $V_{GE} = 0/15 \text{ V}$
 $R_{gon} = 16 \text{ } \Omega$
 $T_j:$ — 25 °C
 — 125 °C
 — 150 °C

figure 42. FWD

Typical reverse recovery time as a function of IGBT turn on gate resistor
 $t_{rr} = f(R_{gon})$

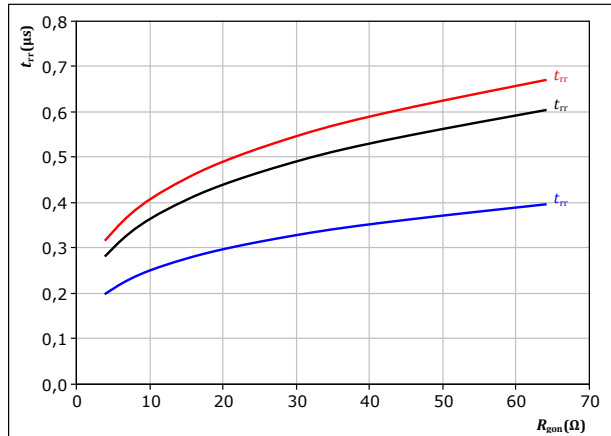

With an inductive load at
 $V_{CE} = 700 \text{ V}$
 $V_{GE} = 0/15 \text{ V}$
 $I_c = 35 \text{ A}$
 $T_j:$ — 25 °C
 — 125 °C
 — 150 °C



Brake Switching Characteristics

figure 43. FWD

Typical recovered charge as a function of collector current

$$Q_r = f(I_c)$$

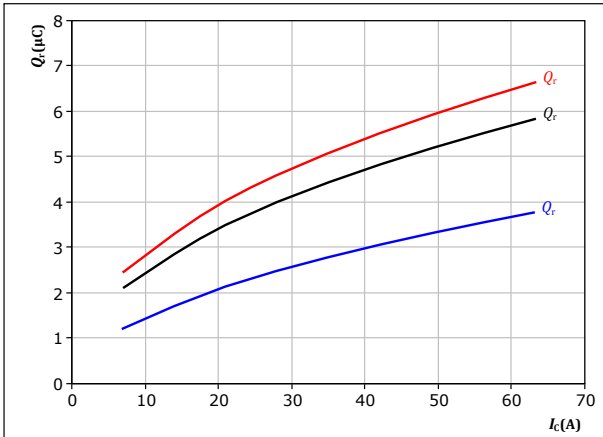

With an inductive load at

$V_{CE} = 700 \text{ V}$
 $V_{GE} = 0/15 \text{ V}$
 $R_{gon} = 16 \text{ } \Omega$

T_j : — 25 °C
— 125 °C
— 150 °C

figure 44. FWD

Typical recovered charge as a function of IGBT turn on gate resistor

$$Q_r = f(R_{gon})$$

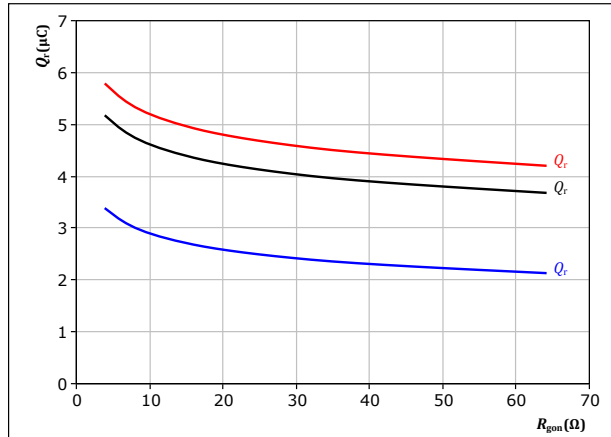

With an inductive load at

$V_{CE} = 700 \text{ V}$
 $V_{GE} = 0/15 \text{ V}$
 $I_c = 35 \text{ A}$

T_j : — 25 °C
— 125 °C
— 150 °C

figure 45. FWD

Typical peak reverse recovery current as a function of collector current

$$I_{RM} = f(I_c)$$

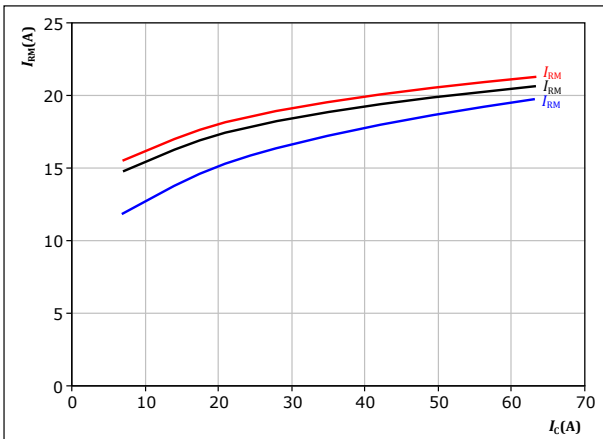

With an inductive load at

$V_{CE} = 700 \text{ V}$
 $V_{GE} = 0/15 \text{ V}$
 $R_{gon} = 16 \text{ } \Omega$

T_j : — 25 °C
— 125 °C
— 150 °C

figure 46. FWD

Typical peak reverse recovery current as a function of IGBT turn on gate resistor

$$I_{RM} = f(R_{gon})$$

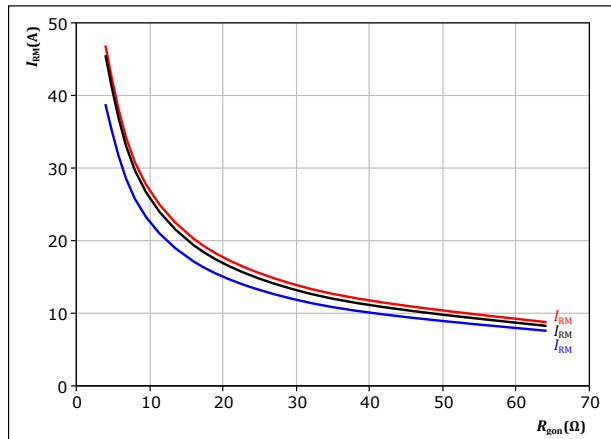

With an inductive load at

$V_{CE} = 700 \text{ V}$
 $V_{GE} = 0/15 \text{ V}$
 $I_c = 35 \text{ A}$

T_j : — 25 °C
— 125 °C
— 150 °C



Brake Switching Characteristics

figure 47. FWD

Typical rate of fall of forward and reverse recovery current as a function of collector current
 $di_f/dt, di_r/dt = f(I_C)$

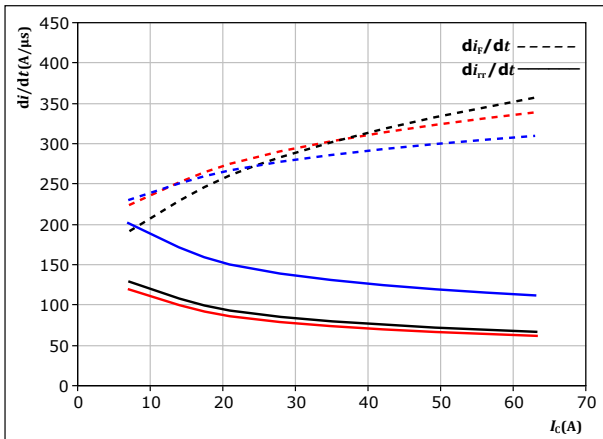

With an inductive load at

$V_{CE} = 700$ V
 $V_{GE} = 0/15$ V
 $R_{gon} = 16$ Ω

T_j : 25 °C
 125 °C
 150 °C

figure 48. FWD

Typical rate of fall of forward and reverse recovery current as a function of turn on gate resistor
 $di_f/dt, di_r/dt = f(R_{gon})$

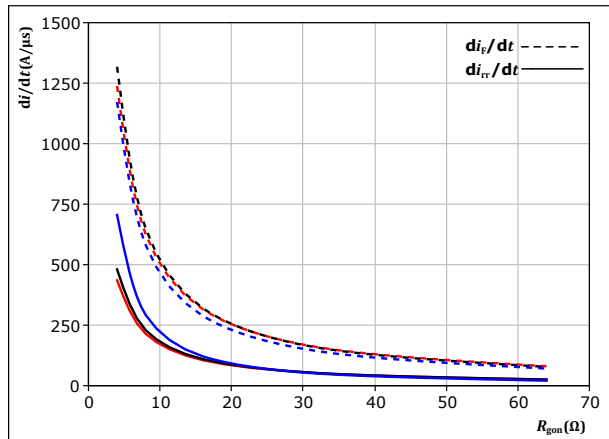

With an inductive load at

$V_{CE} = 700$ V
 $V_{GE} = 0/15$ V
 $I_C = 35$ A

T_j : 25 °C
 125 °C
 150 °C

figure 49. IGBT

Reverse bias safe operating area

$I_C = f(V_{CE})$

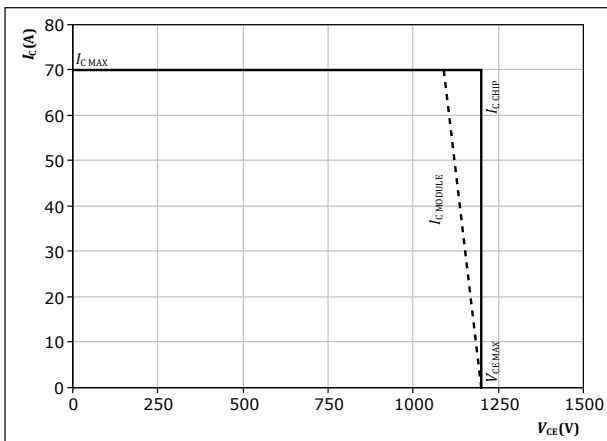

At $T_j = 150$ °C
 $R_{gon} = 16$ Ω
 $R_{goff} = 16$ Ω



Switching Definitions

figure 50. IGBT

Turn-off Switching Waveforms & definition of t_{doff} , t_{Eoff} (t_{Eoff} = integrating time for E_{off})

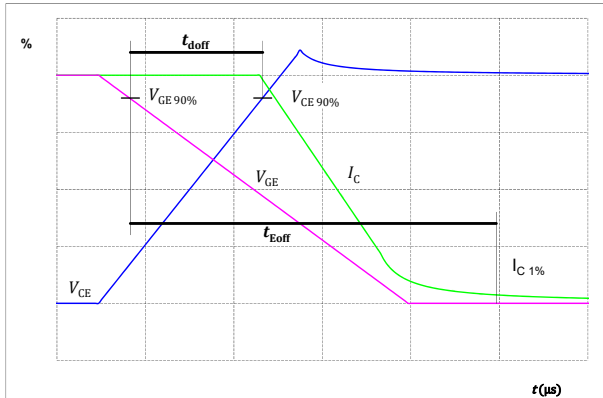

figure 51. IGBT

Turn-on Switching Waveforms & definition of t_{don} , t_{Eon} (t_{Eon} = integrating time for E_{on})



figure 52. IGBT

Turn-off Switching Waveforms & definition of t_f

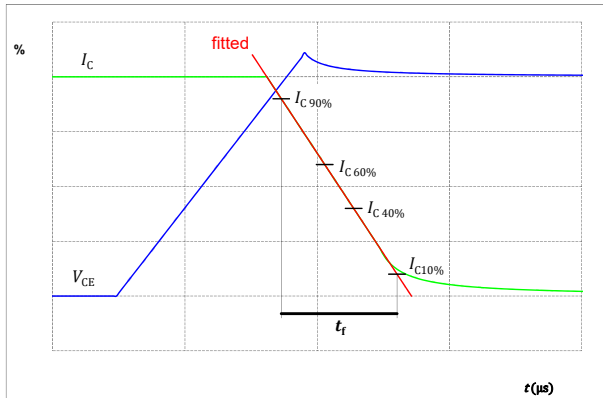
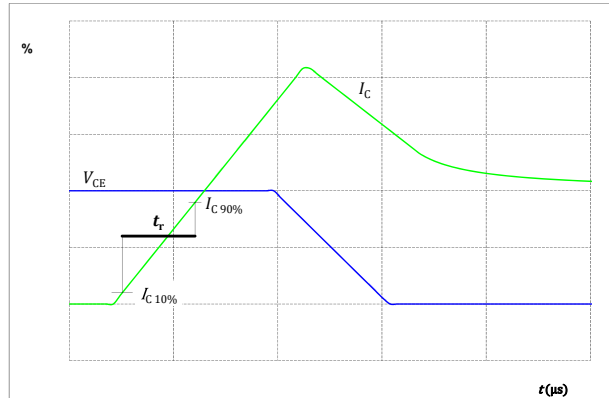

figure 53. IGBT

Turn-on Switching Waveforms & definition of t_r





Switching Definitions

figure 54. FWD

Turn-off Switching Waveforms & definition of t_{rr}

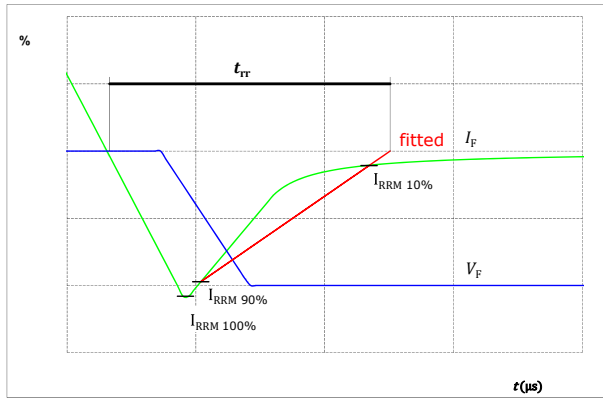
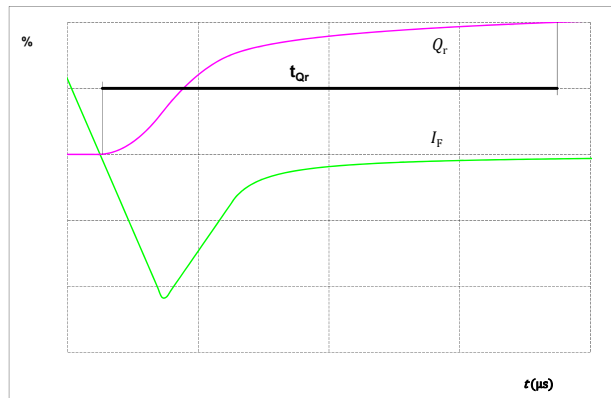

figure 55. FWD

Turn-on Switching Waveforms & definition of t_{Qr} (t_{Qr} = integrating time for Q_r)





Vincotech

10-FY12PMA050M7-P580A78
datasheet

Ordering Code	
Version	Ordering Code
Without thermal paste	10-FY12PMA050M7-P580A78
With thermal paste (5,2 W/mK, PTM6000HV)	10-FY12PMA050M7-P580A78-/7/
With thermal paste (3,4 W/mK, PSX-P7)	10-FY12PMA050M7-P580A78-/3/

Marking						
	Text	Name NN-NNNNNNNNNNNNNN- TTTTIV	Date code WWYY	UL & VIN UL VIN	Lot LLLLL	Serial SSSS
	Datamatrix	Type&Ver TTTTIV	Lot number LLLLL	Serial SSSS	Date code WWYY	

Pin table [mm]			
Pin	X	Y	Function
1	52,55	0	G27
2	47,7	0	DC-Rect
3	44,8	0	DC-Rect
4	37,8	0	DC+Rect
5	37,8	2,8	DC+Rect
6	35	0	DC+Inv
7	35	2,8	DC+Inv
8	28	0	Therm1
9	25,2	0	Therm2
10	22,4	0	DC-3
11	19,6	0	G15
12	16,8	0	S15
13	14	0	DC-2
14	11,2	0	G13
15	8,4	0	S13
16	5,6	0	DC-1
17	2,8	0	G11
18	0	0	S11
19	0	28,5	Ph1
20	2,8	28,5	G12
21	7,5	28,5	S12
22	14,5	28,5	Ph2
23	17,3	28,5	G14
24	22	28,5	S14
25	29	28,5	Ph3
26	31,8	28,5	G16
27	36,5	28,5	S16
28	43,5	28,5	ACIn1
29	52,55	25	ACIn2
30	52,55	16,9	ACIn3
31	52,55	8,6	Br
32	52,55	2,8	DC-Br

Tolerance of pinpositions: ±0,5mm at the end of pins
Dimension of coordinate axis is only offset without tolerance



Vincotech

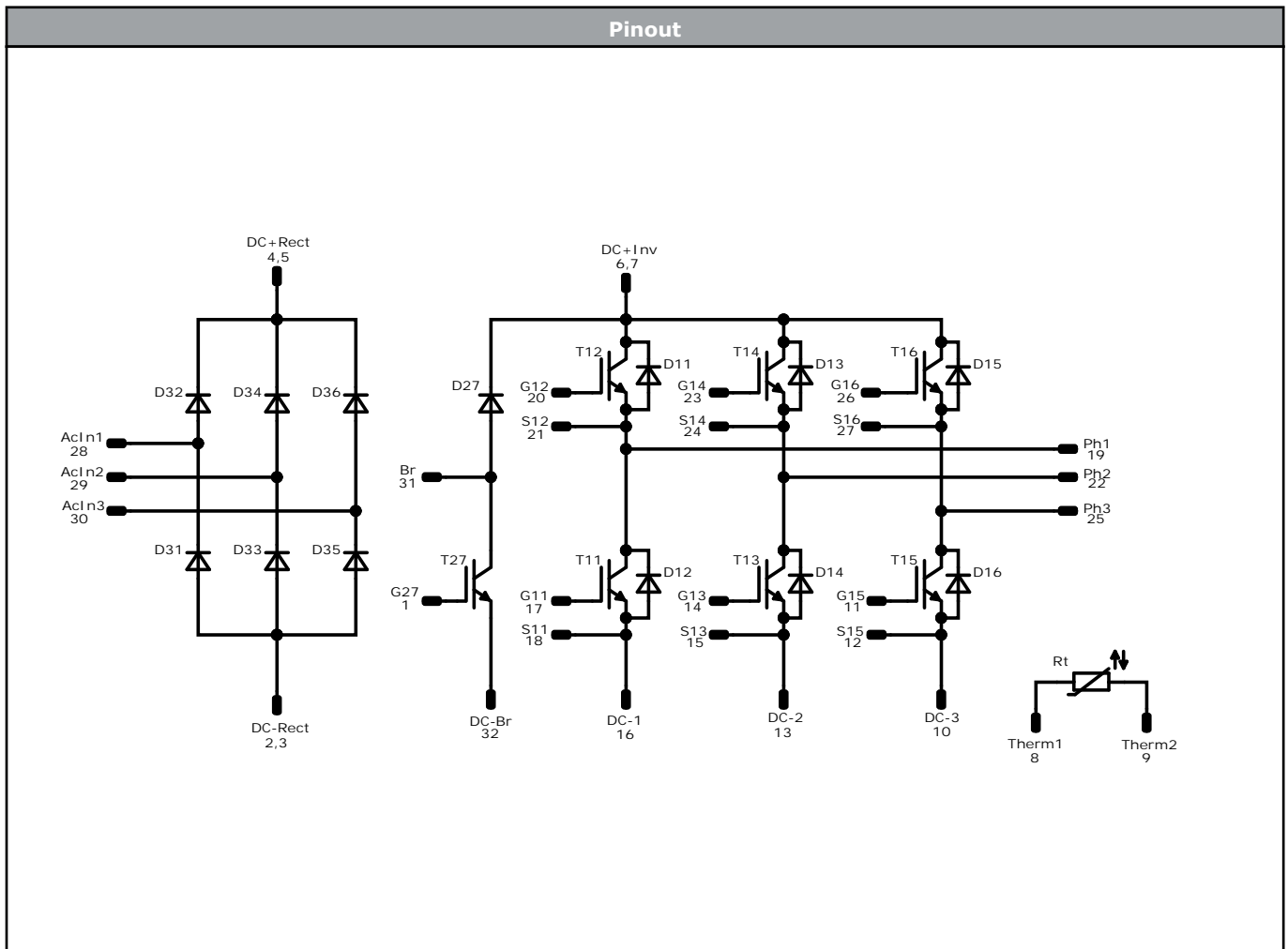

Identification					
ID	Component	Voltage	Current	Function	Comment
T11, T12, T13, T14, T15, T16	IGBT	1200 V	50 A	Inverter Switch	
D11, D12, D13, D14, D15, D16	FWD	1200 V	50 A	Inverter Diode	
T27	IGBT	1200 V	35 A	Brake Switch	
D27	FWD	1200 V	25 A	Brake Diode	
D31, D32, D33, D34, D35, D36	Rectifier	1600 V	45 A	Rectifier Diode	
Rt	NTC			Thermistor	



Packaging instruction				
Standard packaging quantity (SPQ) 100	>SPQ	Standard	<SPQ	Sample

Handling instruction
Handling instructions for <i>flow 1</i> packages see vincotech.com website.

Package data
Package data for <i>flow 1</i> packages see vincotech.com website.

Vincotech thermistor reference
See Vincotech thermistor reference table at vincotech.com website.

UL recognition and file number
This device is certified according to UL 1557 standard, UL file number E192116. For more information see vincotech.com website. 

Document No.:	Date:	Modification:	Pages
10-FY12PMA050M7-P580A78-D4-14	9 Jun. 2022	New Datasheet format, module is unchanged Separate datasheet Correct collector current and continuous forward current Conditions of maximum collector current and continuous forward current added	

DISCLAIMER

The information, specifications, procedures, methods and recommendations herein (together "information") are presented by Vincotech to reader in good faith, are believed to be accurate and reliable, but may well be incomplete and/or not applicable to all conditions or situations that may exist or occur. Vincotech reserves the right to make any changes without further notice to any products to improve reliability, function or design. No representation, guarantee or warranty is made to reader as to the accuracy, reliability or completeness of said information or that the application or use of any of the same will avoid hazards, accidents, losses, damages or injury of any kind to persons or property or that the same will not infringe third parties rights or give desired results. It is reader's sole responsibility to test and determine the suitability of the information and the product for reader's intended use.

LIFE SUPPORT POLICY

Vincotech products are not authorised for use as critical components in life support devices or systems without the express written approval of Vincotech.

As used herein:

1. Life support devices or systems are devices or systems which, (a) are intended for surgical implant into the body, or (b) support or sustain life, or (c) whose failure to perform when properly used in accordance with instructions for use provided in labelling can be reasonably expected to result in significant injury to the user.
2. A critical component is any component of a life support device or system whose failure to perform can be reasonably expected to cause the failure of the life support device or system, or to affect its safety or effectiveness.